

WindMaster™

GILL

and

WindMaster™ PRO

User Manual

3 Axis Ultrasonic Anemometers

1590-PK-020/W (WindMaster) with Firmware 2329-701 and higher

1561-PK-020/W (WindMaster Pro) with Firmware 2329-701 and higher

1590-PK-130/W (WindMaster RA) with Firmware 2329-701 and higher

1590-PK-050 (WindMaster Pipe Mount) with Firmware 2329-701 and higher

Document Number: 1561-PS-0001 Issue 12



WindMaster



WindMaster Pipe Mount



WindMaster RA



WindMaster Pro

Gill Instruments Limited
Saltmarsh Park, 67 Gosport Street, Lymington,
Hampshire, SO41 9EG, UK

Tel: +44 1590 613500, Fax: +44 1590 613555

Email: anem@gillinstruments.com Website: www.gillinstruments.com

Contents

Contents 2

| | |
|--|-----------|
| 1. FOREWORD | 5 |
| 2. INTRODUCTION | 5 |
| 3. PRINCIPLE OF OPERATION | 6 |
| Polar definition | 7 |
| U, V, and W axes definition | 7 |
| Effects of temperature, barometric pressure, rainfall and humidity | 7 |
| Measurement sequence | 8 |
| Signal processing | 8 |
| 4. SPECIFICATION | 9 |
| 5. PRE-INSTALLATION | 11 |
| 5.1. Equipment supplied | 11 |
| 5.2. Software | 11 |
| 5.3. Ordering Options | 11 |
| 5.4. Accessories | 12 |
| 5.5. Packaging | 12 |
| 5.6. Installation requirements | 12 |
| PC requirement | 12 |
| Other equipment | 12 |
| Connection | 12 |
| Power supply | 12 |
| 6. INSTALLATION | 13 |
| 6.1. Installation Guidelines | 13 |
| 6.2. Bench system test | 13 |
| 6.3. Cable type | 13 |
| 6.4. Cable length | 14 |
| 6.5. Grounding (Earthing) | 14 |
| 6.6. Connections | 15 |
| 6.6.1 WindMaster 1590-PK-020/W), WindMaster RA 1590-PK-130/W, WindMaster Pro 1561-PK-020/W), WindMaster Pipe Mount 1590-PK-050 (with Pipe Mount Adaptor removed). | 15 |
| 31 Way Connector Cable Assembly. | 16 |
| Connector Pin & Conductor positions | 17 |
| 6.6.2 WindMaster 1590-PK-050 Pipe Mount Box Connection Details and WindMaster and WindMaster Pro Pipe Mount Box Connection Details (Spared Item 1590-PK-048). | 19 |
| 6.7. Connection to a PC using RS 232 | 22 |
| 6.8. Connection to a PC using RS 422 | 22 |
| 6.9. Connection to a PC via a Power and Communications Interface WindMaster (1590-PK-020/W +options, WindMaster RA (1590-PK-130/W) +options and WindMaster Pro (1561-PK-020/W + options). | 23 |
| Environmental | 23 |
| PCI Electrical Power Requirements | 23 |
| PCI Operation. | 23 |
| Connector Pin and Cable Assignments for PCI/A | 24 |
| PCIA Box (1189-PK-020) WindMaster Analogue Output Connections. | 24 |
| 6.10. Using RS485, 2 Wire, WindMaster/WindMaster Pro Networking | 26 |
| 6.11. Mechanical installation | 27 |
| Location | 27 |
| Orientation | 27 |
| Alignment and Dimensions | 27 |
| Part 1590-PK-130/W North Marker and WindMaster RA Dimensions | 28 |
| Part 1590-PK-050 WindMaster Pipe Mount Dimensions | 29 |
| Corrosion | 29 |
| Grounding (Earthing) | 30 |
| Mounting WindMaster (1590-PK-020/W +options and WindMaster Pro (1561-PK-020/W + options). | 30 |
| Cable strain relief | 30 |

| | |
|--|-----------|
| Flange mounting | 30 |
| Gill Instruments Pipe mount adaptor (1561-PK-026). | 31 |
| Gill Instruments WindMaster 1590-PK-050 Pipe Mount Adaptor. | 32 |
| Gill Instrument Pipe Mount Adaptor 1590-PK-048. | 33 |
| Grounding (Earthing) | 34 |
| 7. MESSAGE FORMATS | 35 |
| 7.1. Mode 1– ASCII, UVW, Continuous | 35 |
| WindMaster Identification node address | 36 |
| Horizontal wind speed | 36 |
| Vertical wind speed | 36 |
| Units | 36 |
| Speed of Sound (SOS) | 36 |
| Sonic temperature | 36 |
| Status | 36 |
| Analogue Inputs (Unit order option) | 36 |
| PRT (Unit order option) | 36 |
| Checksum | 36 |
| Output rate (not displayed) | 36 |
| 7.2. Mode 2 – ASCII, Polar, Continuous (Default Output Parameters in red) | 37 |
| Horizontal wind direction | 38 |
| 7.3. Mode 3–ASCII, UVW, Polled. | 38 |
| Polled Mode Notes General | 39 |
| Syncpoll 0 Mode Notes (Default) | 39 |
| Syncpoll 1 Mode Notes | 40 |
| 7.4. Mode 4 –ASCII, Polar, Polled. | 41 |
| 7.5. Mode 7 –Binary, Polar, Short | 41 |
| 7.6. Mode 8 –Binary, UVW, Short | 41 |
| 7.7. Mode 9 –Binary, Polar, Long | 42 |
| 7.8. Mode 10 –Binary, UVW, Long | 42 |
| 8. ANALOGUE INPUTS | 43 |
| 8.1. Analogue Inputs | 43 |
| 8.2. PRT input | 43 |
| 8.3. Input Rates | 43 |
| 9. ANALOGUE OUTPUTS | 44 |
| 9.1. Output allocations | 44 |
| 9.2. Output types | 44 |
| 9.3. Voltage outputs | 44 |
| 9.4. Current outputs | 44 |
| 9.5. Scaling (metres/second only) | 44 |
| 9.6. Polar wind direction wraparound | 45 |
| 9.7. Speed of Sound and Sonic Temperature | 45 |
| 9.8. Status | 45 |
| 9.9. Default Output | 45 |
| 10. CONFIGURING and VIEWING DATA | 46 |
| 10.1. Configuring with Gill WIND software | 46 |
| 10.2. Configuring WindMaster using a Terminal Program e.g. HyperTerminal. | 50 |
| Setting up | 50 |
| Entering Configuration mode | 50 |
| Returning to Measurement mode | 50 |
| Checking the configuration | 50 |
| Changing settings | 51 |
| Command List | 51 |
| 10.3 Viewing and logging WindMaster Data using Gill WindView Software. | 58 |
| 11 MAINTENANCE & FAULT-FINDING | 61 |
| 11.1 Cleaning | 61 |
| 11.2 Servicing | 61 |
| 11.3 Fault-finding | 61 |
| 11.4 Status (error) codes | 61 |
| 11.5 Returning units | 62 |
| 12 TESTS | 62 |

| | | |
|-------------|--|-----------|
| 12.1 | Bench test | 62 |
| 12.2 | Head Alignment Test | 62 |
| 12.3 | Calibration | 65 |
| | Standard calibration | 65 |
| | Certified calibration | 65 |
| 13 | APPENDICES | 66 |
| 13.1 | Guarantee | 66 |
| 13.2 | Improvement Key Notes | 66 |
| 13.3 | Nakai 2012 Correction Information | 68 |
| 13.4 | Electrical Conformity | 69 |

1. FOREWORD

Thank you for purchasing a WindMaster or WindMaster Pro manufactured by Gill Instruments Ltd. The units have no customer serviceable parts and require no calibration or maintenance. To achieve optimum performance we recommend that you read the whole of this manual before proceeding with use.

Gill products are in continuous development and therefore specifications may be subject to change and design improvements without prior notice.

The information contained in this manual remains the property of Gill Instruments and should not be copied or reproduced for commercial gain.

2. INTRODUCTION

This manual describes the operation of the WindMaster (1590-PK-020/W, 1590-PK-050 Pipe Mount + options), 1590-PK-130/W WindMaster RA (Right Angle Head) and WindMaster Pro (1561-PK-020/W + options).

The term 'WindMaster' is used in this manual as a general term for both the WindMaster and the WindMaster Pro; they are robust three axis anemometers, with no moving parts.

The units of wind speed, output rate, and formats are all user selectable.

The WindMaster, constructed in aluminium and carbon fibre, can perform measurements in wind speeds up to 45 m/s.

The WindMaster Pro, constructed from marine grade stainless steel 316, can perform measurements in wind speeds up to 65 m/s.

Options include up to four analogue input and four analogue output channels (12 or 14 bit resolution for WindMaster; 14 bit resolution for WindMaster Pro, W speed improvement and Sonic Temperature improvement. A PRT input is also available (WindMaster Pro only).

Units may additionally be calibrated in a wind tunnel to ISO 16622, traceable to national standards.

WIND software is available free from the Gill website www.gillinstruments.com. It is strongly recommended as it provides an easy, user-friendly interface to configure the unit.

WINDVIEW software is available free from the Gill website www.gillinstruments.com. It provides a means of viewing data and providing a simple data logging function.

3. PRINCIPLE OF OPERATION

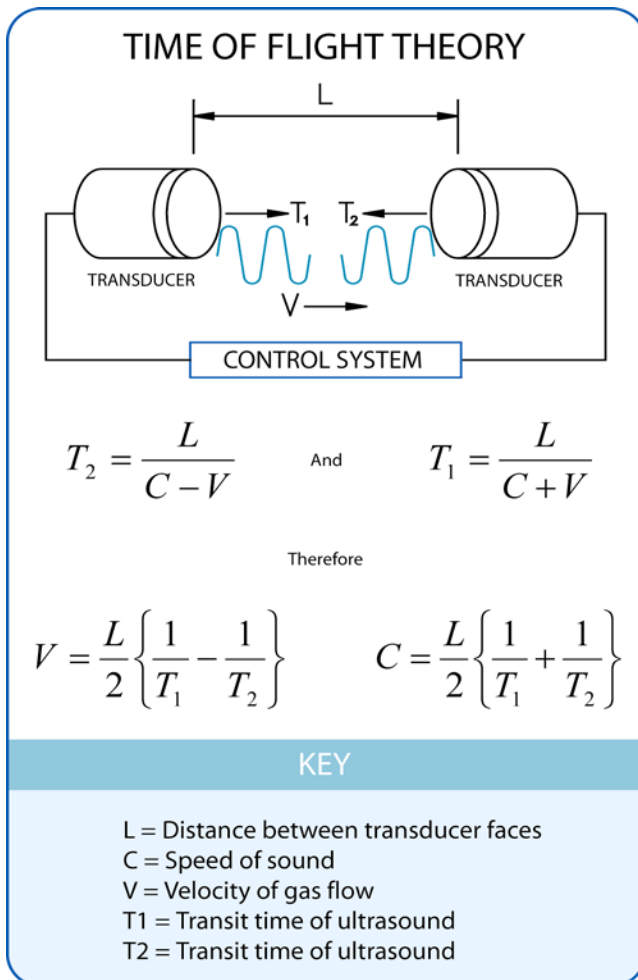

Figure 1 Time of Flight details

The WindMaster measures the times taken for an ultrasonic pulse of sound to travel from an upper transducer to the opposite lower transducer, and compares it with the time for a pulse to travel from lower to upper transducer.

Likewise times are compared between each of the other upper and lower transducers.

As Figure 1 shows, the air velocity along the axis between each pair of transducers can then be calculated from the times of flight on each axis.

This calculation is independent of factors such as temperature.

From the three axis velocities, the wind speed is calculated, as either signed U, V, and W, or as Polar and W.

It can be seen from Figure 1 that the speed of sound in air can be calculated from the times of flight. From this the sonic temperature can be derived from the formula $T_{S1} = C_1^2 / 403$

Where

T_{S1} = Sonic temperature

C_1 = Speed of sound

Note the formula does not account for the effect of Humidity

Crosswind correction is applied to results.

Figure 2 shows the direction and polarity of the U, V and W axes.

Polar definition

The wind speed in the UV plane, with direction in degrees from 0 to 359 °, with respect to the Reference spar (which is normally aligned to North).

U, V, and W axes definition

+U is defined as towards the direction in line with the north spar as indicated in the diagram.

+V is defined as towards the direction of 90° anti-clockwise from N / the Reference spar.

+W is defined as vertically up the mounting shaft.

Note, when the unit is configured for the X2 setting the UV definition rotates 30 degrees anti-clockwise such that U is now in line with transducer axis 1.

Figure 2 U, V and W Axis Definition

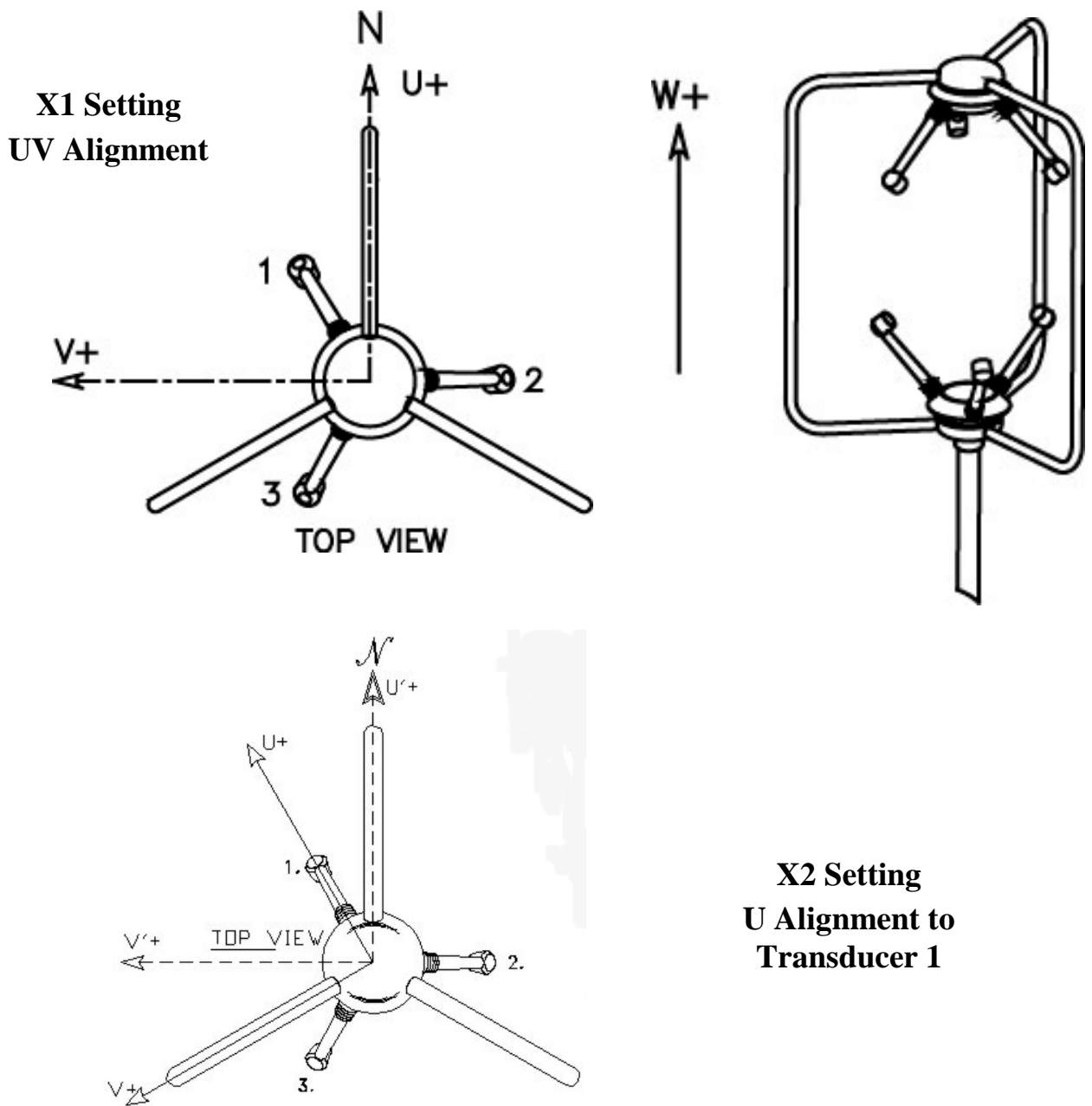

Effects of temperature, barometric pressure, rainfall and humidity

The calculated u, v and w components are independent of temperature, pressure, rainfall & humidity within the operating parameters of the WindMaster.

The calculated sonic temperature/speed of sound should be corrected by the user for humidity to provide an indication of ambient temperature. The calculated Sonic Temperature/Speed of Sound is corrected internally for crosswind.

Measurement sequence

All Modes except Syncpoll 1.

The table shows the firing sequence of the transducers.

Measurement Sequence

The sample rate is automatically selected to either 20Hz or 32Hz, depending on the output rate configured (see section 10.2).

| Measurement Period | Max 50mS (at 20Hz) or 31.25mS (at 32Hz) | | | | | | Next cycle | | | | |
|-----------------------------|---|-------|--------------------|-------|--------------------|-------|---------------------------------|------------|-------|-------|-----------|
| Ultrasonic Measurement Axis | 1 (2mS typical) | | 2 (2mS typical) | | 3 (2mS typical) | | Maths Routine (6mS Typical) | Spare Time | 1 | 2 | |
| Transducer Firing | L > U | U > L | L > U | U > L | L > U | U > L | | | L > U | U > L | L > U etc |
| Analogue Input Measurement | 1, 2, 3 and 4 or PRT | | | | | | | | | | |
| Serial Communication | | | | | | | Data from previous measurement. | | | | |

L > U Indicates lower to upper transducer firing.

U > L Indicates upper to lower transducer firing.

Analogue inputs and PRT are sampled synchronously at rates described in Para 8.3.

Syncpoll 1

In this mode when a Poll command is received it will trigger a single 50mS or 31.25mS ultrasonic measurement as illustrated in the table above and at the same time will trigger a Wind measurement output resultant from the previous polled measurement.

Notes:-

The minimum poll rate supported in this mode is 20Hz.

Analogue inputs are not supported in Syncpoll mode 1.

Signal processing

Instantaneous Sampling

The WindMaster can be configured to output the sampled data direct at the selected output rate without any averaging - "Instantaneous Sampling". Alternatively data can be sampled at 20Hz or 32Hz and averaged (see section 10.2 Fx y and Px). This applies for wind data and speed of sound. All samples are transmitted with a status code.

Retries Enabled

If this mode is selected, if a problem sample is detected, the unit will attempt another ultrasonic firing within the set time parameters.

Calibration Enabled /Disabled

The on-board calibration (providing compensation for spar and transducer shadowing), can be disabled, returning the unit to raw, uncorrected operation

Selection of the above parameters is via using Gill Wind software package or using a Terminal Program to set the FX or Px command.

4. SPECIFICATION

| Parameter | WindMaster/WindMaster RA | WindMaster Pro |
|---|--|--|
| Outputs | | |
| Output rate | 0.25, 0.5, 1, 2, 4, 8, 10, 16, 20, (32 option) Hz | 0.25, 0.5, 1, 2, 4, 8, 10, 16, 20, 32 Hz |
| Sample rate (automatically selected) | 20 or 32 Hz | 20 or 32 Hz |
| Units of measure | m/s, mph, KPH, knots, ft/min | m/s, mph, KPH, knots, ft/min |
| Format | UVW or Polar | UVW or Polar |
| Averaging | Flexible 0 - 3600 s | Flexible 0 - 3600 s |
| Wind Speed | | |
| Range | 0 - 50 m/s | 0 - 65 m/s |
| Resolution | 0.01 or 0.001 m/s | 0.01 or 0.001 m/s |
| Accuracy (12 m/s) (to special order) # | < 1.0 % RMS | < 1.0 % RMS |
| Accuracy (12 m/s) (Standard)* | < 1.5% RMS | < 1.5% RMS |
| 'w' improvement multiplication factor applied as table, allows comparison to data previously collected with older WindMaster units with firmware 2329-601 or lower without multiplication factor. | w component only: +w = 1.166, -w = 1.289 | w component only: +w = 1.166, -w = 1.289 |
| Direction | | |
| Range | 0 – 359.9° | 0 – 359.9° |
| Resolution | 1° or 0.1° | 1° or 0.1° |
| Accuracy (12 m/s) (Standard)* | 2° | 2° |
| Accuracy (12 m/s) (to special order)* # | 0.5° | 0.5° |
| Speed of Sound | | |
| Range | 300 -370 m/s | 300 -370 m/s |
| Resolution | 0.01 m/s | 0.01 m/s |
| Accuracy | < ± 0.5% @ 20°C | < ± 0.5% @ 20 °C |
| Power requirement | | |
| | 9 -30 V dc, (55 mA @ 12 V dc) (excluding analogue outputs) | 9 -30 V dc, (55 mA @ 12 V dc) (excluding analogue outputs) |
| Digital output | | |
| Protocol (ASCII and Binary) | RS232, RS422, (RS485 WindMaster Networking) | RS232, RS422, (RS485 WindMaster Networking) |
| Baud rates | 2400 - 57600 | 2400 - 57600 |
| Analogue outputs (optional) | | |
| 4 channels | Resolution 12 or 14 bit | Resolution 14 bit |
| Selectable range | User selectable full scale wind speed | User selectable full scale wind speed |
| Output type | 0-20 mA, 4-20 mA, 0-5V, ±5V, ±2.5V | 0-20 mA, 4-20 mA, 0-5V, ±5V, ±2.5V |
| Analogue inputs (optional) | | |
| Up to 4 single-ended or 2 differential | Resolution 12 or 14 bit | Resolution 14 bit, plus PRT 100ohm (option) |
| Input range | ±5 V | ±5 V |
| Sonic temperature | | |
| Range | -40 °C to +70 °C | -40 °C to +70 °C |
| T _s ' Accuracy (≥ 1 Hz) (All models, unchanged) | Eddy Covariance Quality | Eddy Covariance Quality |
| T _s Accuracy (slow response, used as ambient thermometer, unit firmware 2329-700 or higher) | ± 2°C between -20° C to +30° C | ± 2°C between -20° C to +30° C |

| | | |
|-----------------------|---|---|
| PRT (Optional) | | |
| Resolution | Not Applicable | 0.01°C |
| Measurement Accuracy | Not Applicable | <±0.1 °C (-40 to +50°C) |
| Measurement Accuracy | Not Applicable | <±0.15°C (+50 to +70°C) |
| General | | |
| Weight | 1.0kg (1590-PK-020 /W and 1590-PK-130/W). | 1.7kg (1561-PK-020 /W) |
| Size | 2.12kg (1590-PK-050) 750mm x 240mm (1590-PK-020/W) 580mm x 323mm (1590-PK-130/W) 952mm x 240mm (1590-PK-050) | 750mm x 240mm (1561-PK-020/W) |
| Environmental | IP65 | IP65 |
| Operating temperature | -40 °C to +70 °C | -40 °C to +70 °C |
| Humidity | < 5 % to 100 % | < 5 % to 100 % |
| Precipitation | Operation up to 300 mm / hour | Operation up to 300 mm / hour |
| EMC | Emissions BS EN 61000 - 6 - 3 Immunity BS EN 61000 - 6 - 2 | Emissions BS EN 61000 - 6 - 3 Immunity BS EN 61000 - 6 - 2 |

* WindMaster/WindMaster Pro Accuracy specification applies for wind speed up to range maximum, and for wind incidence up to ± 30 ° from the horizontal on units with firmware 2329-700 and higher.

Custom calibration (to be specified when ordering, or unit can be returned for calibration) - Wind tunnel calibration is in accordance with ISO 16622 and traceable to national standards.

5. PRE-INSTALLATION

5.1. Equipment supplied

WindMaster 1590-PK-020/W, WindMaster RA 1590-PK-130/W or WindMaster Pro 1561-PK-020/W

Connector assembly comprising 31 way Clipper connector.
Solder bucket pins.
Sealing gland and washer.

Installation kit Four M6 stainless steel nuts, bolts and shake-proof washers.
User Manual (this document) on a CD.

WindMaster 1590-PK-050 Pipe Mount Unit

Installation kit Two 45mm Stainless Steel Jubilee Clips.
Three slotted M5x10mm set screws.

One M4 stainless steel screw, spring washer, washer and crimp ring terminal.

User Manual (this document) on a CD.

5.2. Software

WIND software supplied on the User CD is also available free at www.gillinstruments.com, and is strongly recommended as it provides an easy, user-friendly interface to configure the WindMaster/Pro unit.

WINDVIEW software supplied on the User CD is also available free at www.gillinstruments.com, and it provides an interface to view and log WindMaster/Pro data.

5.3. Ordering Options

Notes These options must be specified when ordering the WindMaster or WindMaster Pro.

| Option | WindMaster/ WindMaster RA | WindMaster Pro | Software Serial Number Prefix Identification |
|--|--|------------------------------------|--|
| Improved W Speed and Improved $\pm 2^{\circ}\text{C}$ Sonic Temperature Performance (See Appendix A) | 1590-PK-020/W, 1590-PK-130/W and 1590-PK-050 | 1561-PK-020/W | Wxxxxxx |
| Four Analogue outputs (See Note 2) | 12 or 14 bit (specify on order) | 14 bit Specify when ordering | Not Applicable |
| Four Analogue inputs (See Note 2) | 12 or 14 bit (specify on order) 1590-PK-050 12 bit fitted | 14 bit Specify when ordering | Not Applicable |
| PRT input (See Note 2) | Not available | Specify when ordering | Not Applicable |
| 32Hz (See Note 2) | Specify when ordering | Not Applicable | Not Applicable |
| Wind tunnel calibration, traceable to national standards (See Note 1) | Specify when ordering (See Note 1) | Specify when ordering (See Note 1) | Not Applicable |

Note 1, Units may be returned to Gill Instruments for Wind tunnel calibration.

Note 2, Implemented options are identified on the unit label with a against the option description.

The picture opposite shows a unit with options for:-

- 4 x 14 bit I/P
- 4 x 14bit O/P
- PRT
- 32Hz



5.4. Accessories

| Item | Part No |
|---|-----------------|
| Travelling case - Portable protective case (WindMaster not for part 1590-PK-050) | 1210 – 30 - 074 |
| Travelling case - Portable protective case (WindMaster Pro) | 1561 - 00 - 028 |
| 31 way Clipper connector | 1561 - PK - 050 |
| 15m, 9 Pair, twisted pair screened, 22AWG lead - one end free, other end fitted with Clipper pins | 1561 - 10 - 018 |
| Power Supply and Interface Unit (PCI) | 1189 - PK - 021 |
| Pipe Mount Adaptor ,1.5"/48.3mm (not part of WindMaster 1590-PK-050) | 1561 - PK - 026 |
| Pipe Mount Adaptor with Interface box for 1.32"/33.4mm pipe. | 1590 - PK - 048 |

5.5. Packaging

Whilst the WindMaster is being moved to its installation site, the unit should be kept in its packaging. All the packaging should be retained for use if the unit has to be returned at any time.

Note that if the WindMaster is to be regularly moved around, a travelling case is available as an optional extra.

5.6. Installation requirements

PC requirement

WIND and *WINDVIEW* software will operate with any PC with Windows software up to at least Windows 10 versions.

The PC must be fitted with a suitable interface to match the chosen communication format - RS232, RS422, or RS485 point to point. Alternatively a Gill Power Supply and Interface (PCI) may be used to convert RS422/485 output to RS232.

Other equipment

Analogue inputs / outputs must be compatible with the options fitted to the WindMaster or WindMaster Pro. See Sections 8 and 9.

Connection

- The WindMaster/Pro unit is fitted with a 31 way Clipper industrial plastic socket and supplied with a modified mating plug (shell size 3) with solder bucket pins.
- The cable should be securely fixed with cable clamps or equivalent, so that the cable is not under stress at the plug.
- There are restrictions on the maximum cable lengths for correct operation. See 6.4.
- The cable should be routed up the inside of the mounting tube.
- See 6.3 for cable specification.

Power supply

- The WindMaster requires a DC supply of between 9 – 30 V DC.
- Typical current drain 55 mA @ 12 V (excluding analogue outputs).
- Allow up to a further 80mA maximum if four 4-20mA analogue connections are used.

6. INSTALLATION

6.1. Installation Guidelines

As with any sophisticated electronics, good engineering practice should be followed to ensure correct operation.

- Always check the installation to ensure the WindMaster is not affected by other equipment operating locally, which may not conform to current standards, e.g. radio/radar transmitters, boat engines, generators etc.
- Guidelines –
 - Avoid mounting in the plane of any radar scanner – a vertical separation of at least 2m should be achieved.
 - Radio transmitting antennas, the following minimum separations (all round) are suggested.
 - VHF IMM – 1m
 - MF/HF – 5m
 - Satcom – 5m (avoid likely lines of sight)
- Use cables recommended by Gill. If cables are cut and re-connected incorrectly (perhaps in a junction box) then EMC performance may be compromised if cable screen integrity is not maintained.
- Earth loops should not be created – wire the system in accordance with the installation guidelines.
- Ensure the power supply operates to the WindMaster specification at all times.
- Avoid turbulence caused by surrounding structures that will affect the accuracy of the WindMaster such as trees, masts and buildings.
- The World Meteorological Organisation makes the following recommendation:
- The standard exposure of wind instruments over level open terrain is 10m above the ground. Open terrain is defined as an area where the distance between the sensor and any obstruction is at least 10 times the height of the obstruction.
- If the sensor is to be mounted on a mast boom, part way up a tower or mast, then the boom should be at least twice as long as the minimum diameter or diagonal of the tower. The boom should be positioned on the prevailing wind side of the tower.
- If mounted on a pole then as a guide the distance from an adjacent pole should be 10 times the other pole diameter.
- If mounting on a building then as a guide the sensor should be mounted at a height of 1.5 times the height of the building.
-

6.2. Bench system test

Note: Prior to physically mounting the WindMaster in its final location, we strongly recommend that a bench system test be carried out to confirm the system is configured correctly, is fully functional and electrically compatible with the selected host system and cabling (preferably utilising the final cable length). The required data format, units, output rate, and other options should also all be configured at this stage.

6.3. Cable type

An RS232 / RS422 compatible cable (as appropriate) should be used, with the number of twisted pairs matching the application.

Generic description – Twisted pairs with drain wire, screened with aluminised tape, with an overall PVC sheath. Typical Wire size 7/0.2mm (24 AWG), 22AWG wire may also be used.

Gill 15m lead - A nine pair, 22AWG, 15metre lead, with one end free and the other end fitted with Clipper pins, is available as an accessory from Gill, see 5.4 Accessories for part number.

The table shows some suitable manufacturers' references; other manufacturers' equivalents can be used.

| No. of pairs | Gill ref. | Belden ref. | Batt electronics ref. |
|--------------|-------------|-------------|-----------------------|
| 9 | 026 - 02663 | 8774 | 91009 |

The cable allows for the connection of all: -

Power inputs.

Digital data inputs and outputs.

Analogue inputs.

Analogue Outputs.

Note: If PRT input option is selected customer must compromise on the number of enclosed inputs or outputs. If a PRT is connected you must sacrifice two analogue inputs or outputs.

Other example twisted pair screened cable types (24AWG) are:-

| No. of pairs | Gill ref. | Belden ref. | Batt electronics ref. |
|--------------|-------------|-------------|-----------------------|
| 2 | - | 9729 | - |
| 3 | 026 - 02660 | 9730 | 91030 |
| 4 | 026-03156 | 9728 | 91199 |
| 6 | - | 9731 | 91031 |

6.4. Cable length

The maximum cable length is dependent on the chosen communication format (RS232, RS422 or RS485), the baud rate, and, to a lesser extent, on the cable type and the local electrical 'noise' level.

| Communication format | Baud rate | Max. cable length |
|----------------------------|-----------|---|
| RS232 | 9600 | 6.5 m (20 ft) or if using Cat 5 cable see manufacturers recommendations |
| RS422/485 | 9600 | 1 km (3200 ft) |
| Analogue outputs - voltage | N/A | 6.5 m (20 ft) |
| Analogue outputs - current | N/A | Resistance dependent (max 300 Ω) |

The above table shows the typical maximum lengths at the given baud rates, using the recommended cable. If any problems of data corruption etc. are experienced, then a slower baud rate should be used. Alternatively, a thicker or higher specification cable can be tried.

6.5. Grounding (Earthing)

To ensure correct operation, and for maximum protection against lightning, the anemometer **MUST** be correctly grounded (earthed) via its mountings. Inadequate grounding will degrade anemometer performance, particularly in the presence of radio frequency interference.

The unit **MUST** be connected to an appropriate grounding point with a minimum of 6mm² copper wire, via the M6 base screws. The primary earth for the anemometer must be provided via the base screws and not via the cable screens.

6.6. Connections

Important

- **Do NOT join any of the cores of the cable together.**
- **Any cores not used should be isolated.**
- **Do NOT connect the unit's analogue output 0V or power 0V to the screen or ground / earth.**
- **The integrity of the screen of each pair should be maintained throughout the cable run.**
- **Avoid long grounding loops.**
- **For maximum lightning protection it is essential that the unit be properly grounded via its mounting base.**

6.6.1 WindMaster 1590-PK-020/W), WindMaster RA 1590-PK-130/W, WindMaster Pro 1561-PK-020/W), WindMaster Pipe Mount 1590-PK-050 (with Pipe Mount Adaptor removed).

31 Way Base Connector

| Function | Remarks | 31 way Connector Pin No |
|---------------------|--|-------------------------|
| TXA (-) | Anemometer Transmit - | 1 |
| TXB (+) | Anemometer Transmit + | 2 |
| RXB (+) | Anemometer Receive + | 5 |
| RXA (-) | Anemometer Receive - | 6 |
| Communications Mode | Polarity sets Comms mode Connect to V+ for RS232 Connect to 0v for RS422/RS485 | 4 |
| Power V+ | 9 – 30 V | 11 |
| Power 0V | Use also for digital comms 0V | 12 |
| Analogue Output 1 | Option | 8 |
| Analogue Output 2 | Option | 14 |
| Analogue Output 3 | Option | 9 |
| Analogue Output 4 | Option | 15 |
| PRT Excitation + | Option | 19 |
| PRT Excitation - | Option | 20 |
| PRT Sense + | Option | 25 |
| PRT Sense - | Option | 26 |
| Analogue Input 1 | Option | 27 |
| Analogue Input 2 | Option | 28 |
| Analogue Input 3 | Option | 29 |
| Analogue Input 4 | Option | 24 |
| Analogue Grounds | Use the most convenient pin | 10, 16, 17 |
| Screens | Use the most convenient pin | 3, 7, 21, 30, 31 |
| Not Connected | | 13, 18 |

31 Way Connector Cable Assembly.

Open the pack of parts (1561-PK-050) provided with the WindMaster (not Pipe Mount units).

Strip the cable and solder the contact pins to the cores (please note that the connector supplies the correct strain relief for cables with an outside diameter of 6-12mm).

Put the parts on the cable in the order as shown below.



Trim back the screened cable outer and screen sleeves 40mm.

Trim back the screen drain wires flush with the outer sleeve.

Strip back the connection wires by 5mm and tin solder.

Solder the contact pins to the wires (please note that the connector supplies the correct strain relief for cables with an outside diameter of 6-12mm).

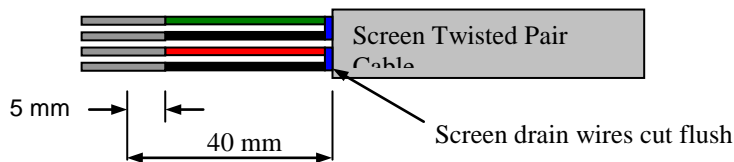

Whilst squeezing the red retainers in the direction of ARROW A, pull in the direction of ARROW B.

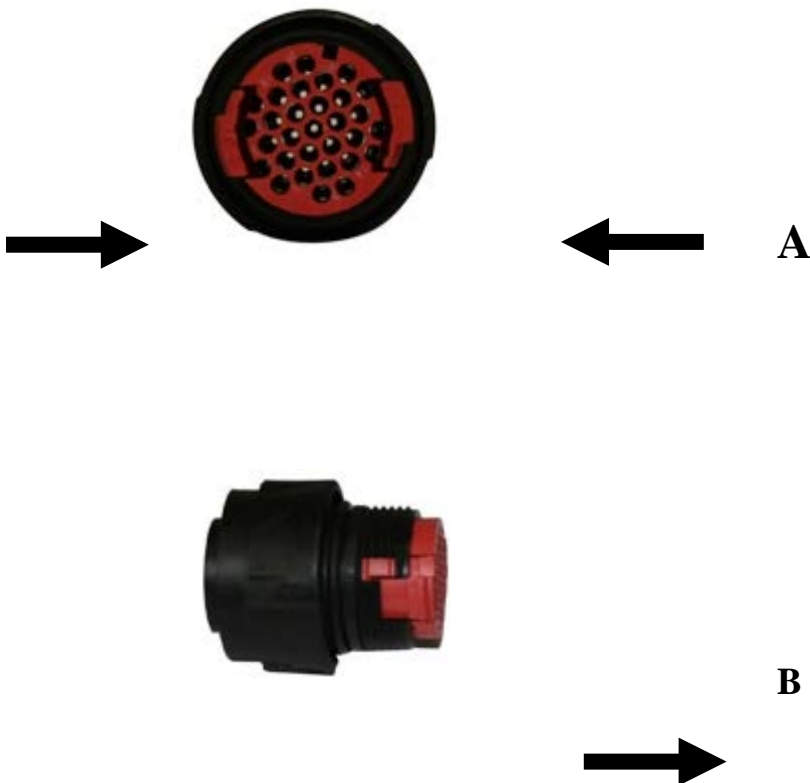

Your connector should now resemble the connector in the picture above.

Insert each contact pin until you feel a slight click. If you have inserted the contact into the incorrect hole it can be removed at this point by simply pulling it out. Please note there will be some resistance.



Continue to insert all of the contacts you require in accordance with the diagram below.

Connector Pin & Conductor positions

Supplied WindMaster Connector



WindMaster Base socket

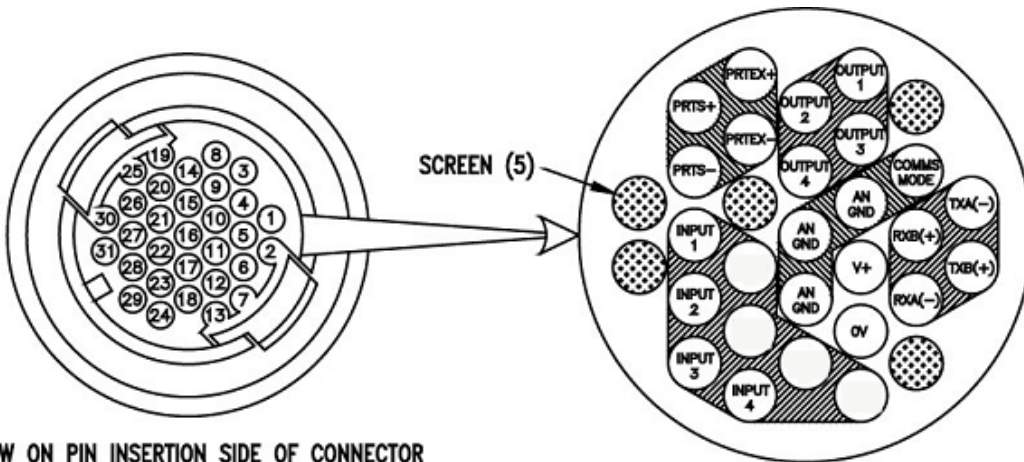
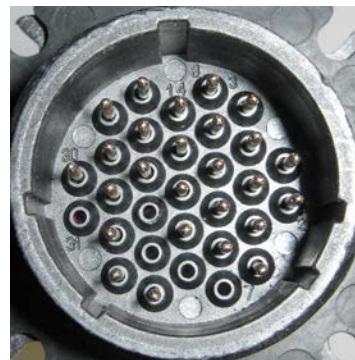

VIEW ON PIN INSERTION SIDE OF CONNECTOR

The drawing above shows the pin positions of the wire conductors, together with position of conductor screens. This information must be used in conjunction with the information shown in Para 6.6 connections. If the PRT option is selected you may have to sacrifice two analogue inputs or outputs.

Once all of the contacts are inserted push the red retainer into place.

NB. The retainer can only be pushed back into place if the contacts are fully engaged.

Fit the connector to the WindMaster so that you can now finish assembling the connector.

Screw the back-shell onto the connector until it is fully in place. Please note that the final rotations can be slightly stiff



Screw the cable clamp into the back shell

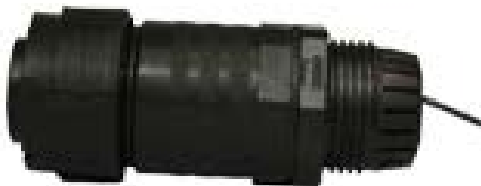

Now screw the cable-clamping nut into place



The connector can now be removed from the WindMaster.

6.6.2 WindMaster 1590-PK-050 Pipe Mount Box Connection Details and WindMaster and WindMaster Pro Pipe Mount Box Connection Details (Spared Item 1590-PK-048).

See also the next page.

| Part | | WindMaster 1590-PK-050 Pipe Mount Integral Part | Pipe Mount Adaptor 1590-PK-048 Spared Item |
|----------------------|----------|--|--|
| Connector | Terminal | Connection Name | Connection Name |
| J1 | | PRT Excite + (No Connection) | PRT Excite + (wired connection) |
| | | PRT Excite – (No Connection) | PRT Excite – (wired connection) |
| | | PRT Sense + (No Connection) | PRT Sense + (wired connection) |
| | | PRT Sense – (No Connection) | PRT Sense – (wired connection) |
| | | Screen Ground from WindMaster | Screen Ground from WindMaster |
| | | Com (communication) Mode (External Link to determine RS232 or RS422/RS485) | Com (communication) Mode (External Link to determine RS232 or RS422/RS485) |
| | | Power 0V | Power 0V |
| | | Power +V | Power +V |
| J2 | | Anemometer Transmit TXA (-) | Anemometer Transmit TXA (-) |
| | | Anemometer Transmit TXB (+) | Anemometer Transmit TXB (+) |
| | | Anemometer Receive RXA (-) | Anemometer Receive RXA (-) |
| | | Anemometer Receive RXB (-) | Anemometer Receive RXB (-) |
| | | Analogue Out 4 (No Connection) | Analogue Out 4 (wired connection) |
| | | Analogue Out 3 (No Connection) | Analogue Out 3 (wired connection) |
| | | Analogue Out 2 (No Connection) | Analogue Out 2 (wired connection) |
| | | Analogue Out 1 (No Connection) | Analogue Out 1 (wired connection) |
| J3 | | Analogue In 1 | Analogue In 1 |
| | | Analogue Ground | Analogue Ground |
| | | Analogue In 2 | Analogue In 2 |
| | | Analogue Ground | Analogue Ground |
| | | Analogue In 3 | Analogue In 3 |
| | | Analogue Ground | Analogue Ground |
| | | Analogue In 4 | Analogue In 4 |
| | | Analogue Ground | Analogue Ground |
| J4 (Jumper) | Com-CM | Communication mode set by external connection (Default Setting) | Communication mode set by external connection (Default Setting) |
| | Com-OV | Set communication mode to RS422/RS485 (Internal Link, external link unnecessary) | Set communication mode to RS422/RS485 (Internal Link, external link unnecessary) |
| | Com-V+ | Set communication mode to RS232 (Internal Link, external link unnecessary) | Set communication mode to RS232 (Internal Link, external link unnecessary) |
| Screen Ground Pillar | Screen | The cable screen from the WindMaster 31 way connector is wired to a Ground Pillar | The cable screen from the WindMaster 31 way connector is wired to a Ground Pillar |
| Screen Ground Pillar | Screen | The cable screen/s from user equipment is wired to this Pillar using M4 screw/washer/terminal fixings supplied in the installation kit | The cable screen/s from user equipment is wired to this Pillar using M4 screw/washer/terminal fixings supplied in the installation kit |

WindMaster 1590-PK-048 Pipe Mount Box Connection Schematic

J4, Comms Link Positions.

Solid line is default (COM to CM).

Move to COM and V+ for RS232 only if not using an external wire link to set RS232 operation.

Move to COM and 0V for RS422/RS485 only if not using an external wire link to set RS422/RS485 operation.

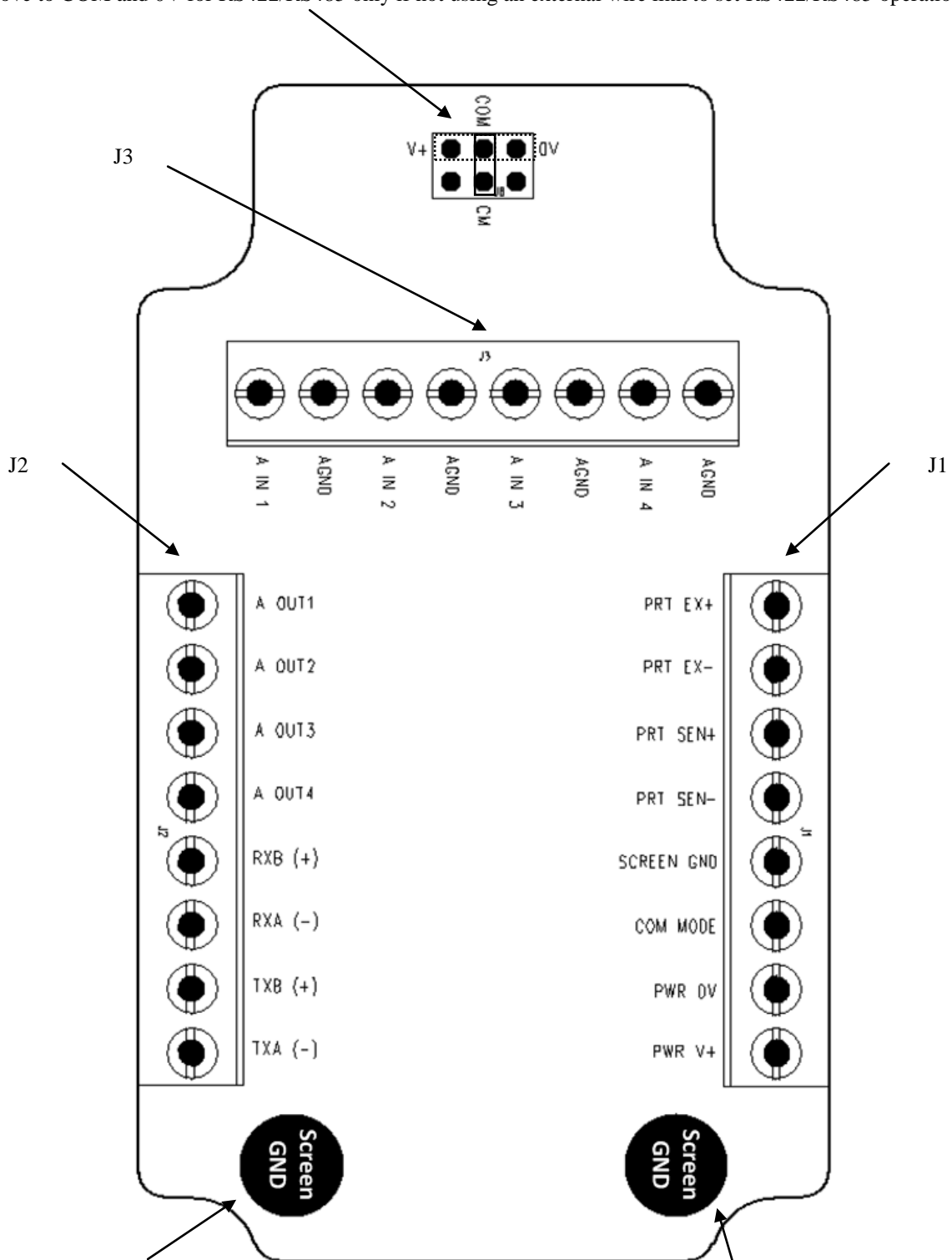

WindMaster 31 Way connector cable screen connected to a crimp terminal screwed to the hexagonal pillar.

User equipment

The cable screen/s from user equipment are wired to this Pillar using M4 screw, washers and terminal fixings supplied in the installation kit 1590-PK-045 or 1590-PK-046.

Note: The M20 cable gland outlet on the Pipe Mount box is designed to accept cables with an outer diameter between 8mm to 13mm.

31 Way Connector to PCB Wiring Loom Details

Note:-

WindMaster Part 1590-PK-050, the WindMaster 31 way connector wires 8, 9, 14, 14, 19, 20, 25 and 26 are not fitted.

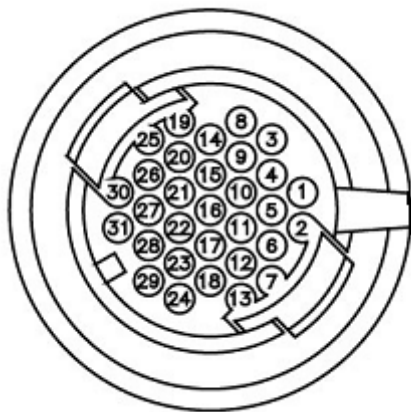

VIEW ON PIN INSERTION SIDE OF CONNECTOR

| PIN NUMBER | WIRE COLOUR | FUNCTION |
|------------|-------------|---------------------|
| 1 | GREEN | TXA (-) |
| 2 | BROWN | TXB (+) |
| 3 | GREY | SCREENS |
| 4 | BLUE | COMMUNICATIONS MODE |
| 5 | YELLOW | RXB (+) |
| 6 | WHITE | RXA (-) |
| 10 | VIOLET | ANALOGUE GROUND |
| 11 | RED | POWER V+ |
| 12 | BLACK | POWER DV |
| 24 | ORANGE | ANALOGUE INPUT 4 |
| 27 | GREEN | ANALOGUE INPUT 1 |
| 28 | BROWN | ANALOGUE INPUT 2 |
| 29 | GREY | ANALOGUE INPUT 3 |
| 8 | GREEN | ANALOGUE OUTPUT 1 |
| 9 | BROWN | ANALOGUE OUTPUT 3 |
| 14 | GREY | ANALOGUE OUTPUT 2 |
| 15 | BLUE | ANALOGUE OUTPUT 4 |
| 19 | YELLOW | PRT EXCITATION + |
| 20 | WHITE | PRT EXCITATION - |
| 25 | VIOLET | PRT SENSE + |
| 26 | ORANGE | PRT SENSE - |

31 Way Connector →

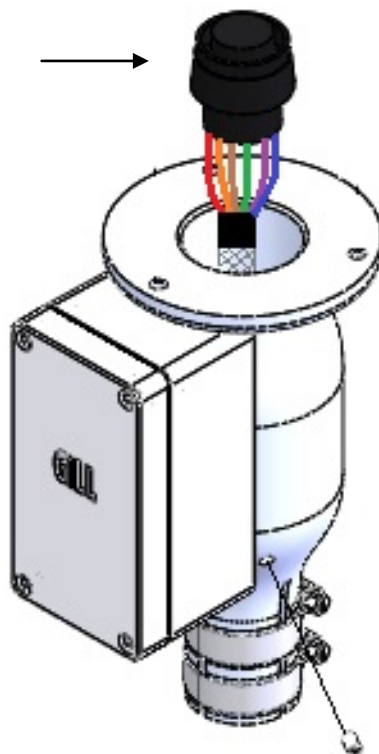

6.7. Connection to a PC using RS 232

Notes:-

1. Using RS232, the cable length for reliable operation is limited to 6.5m (20ft) @ 9600 Baud. See 6.4
2. For longer cable runs, we recommend using the WindMaster configured with RS422 output, and a RS422/232 converter at the PC.
3. Ensure WindMaster is configured for AUTO or RS232. See Section 10 Configuring.
4. On Pipe Mount box units set J4 Link to COM/CM and externally link Comms mode to Power V+ or internally move J4 link from COM/CM to between COM and V+.
5. On non-pipe mount box units if Pin 4 is left open circuit the unit will default to RS422 operation in Auto mode.

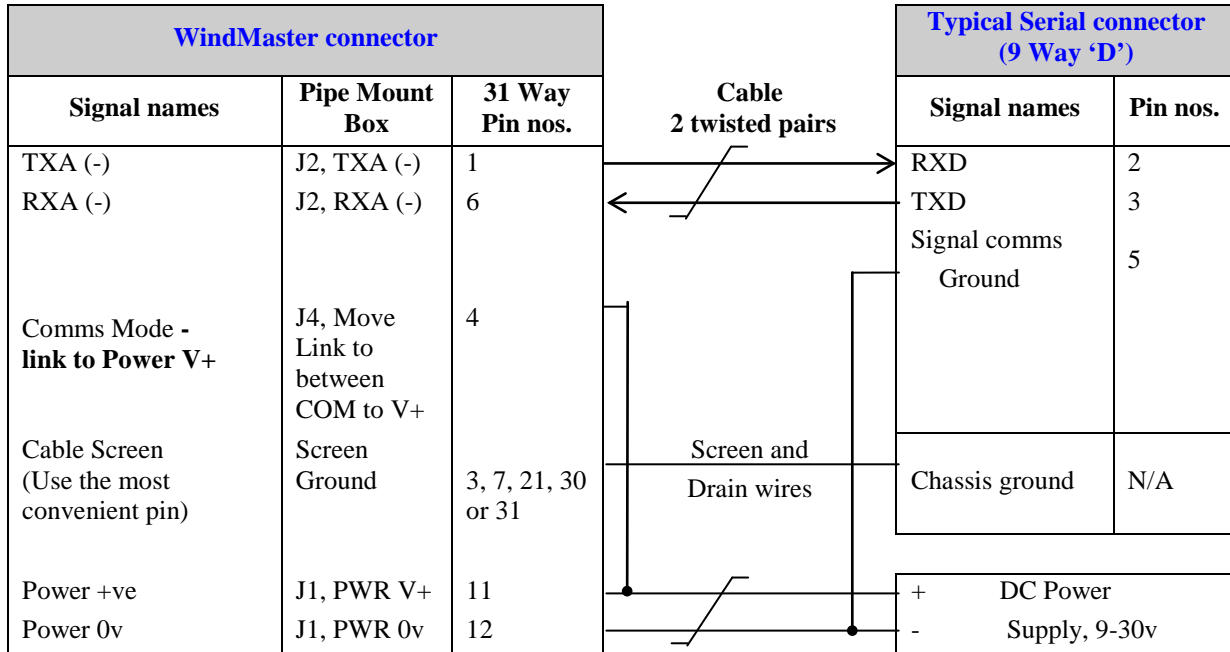

6.8. Connection to a PC using RS 422

Notes:-

1. The PC must be fitted with an internal or external RS422 to RS232/USB converter.
2. On Pipe Mount box units set J4 Link to COM/CM and externally link Comms mode to Power 0v or internally move J4 link from COM/CM to between COM and 0v.
3. Configure WindMaster for RS 422 by linking Comms Mode line (Pin 4) to 0V (Pin 12).
4. On non-pipe mount box units if Pin 4 is left open circuit the unit will default to RS422 operation in Auto mode.

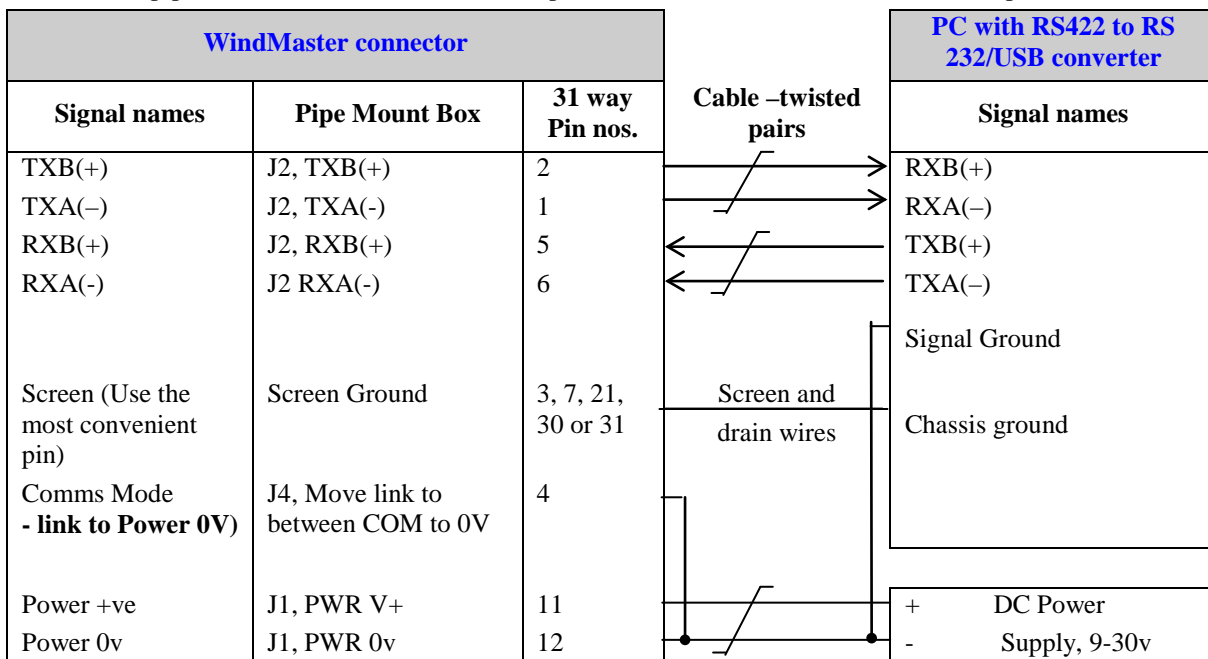

6.9. Connection to a PC via a Power and Communications Interface WindMaster (1590-PK-020/W +options, WindMaster RA (1590-PK-130/W) +options and WindMaster Pro (1561-PK-020/W +options).

Dependent upon system requirements the WindMaster unit can be operated with the Power and Communications and Interface unit (PCI), which can be ordered as an optional extra. Connect WindMaster via RS422 port; then connect computer to RS232 port on PCI.

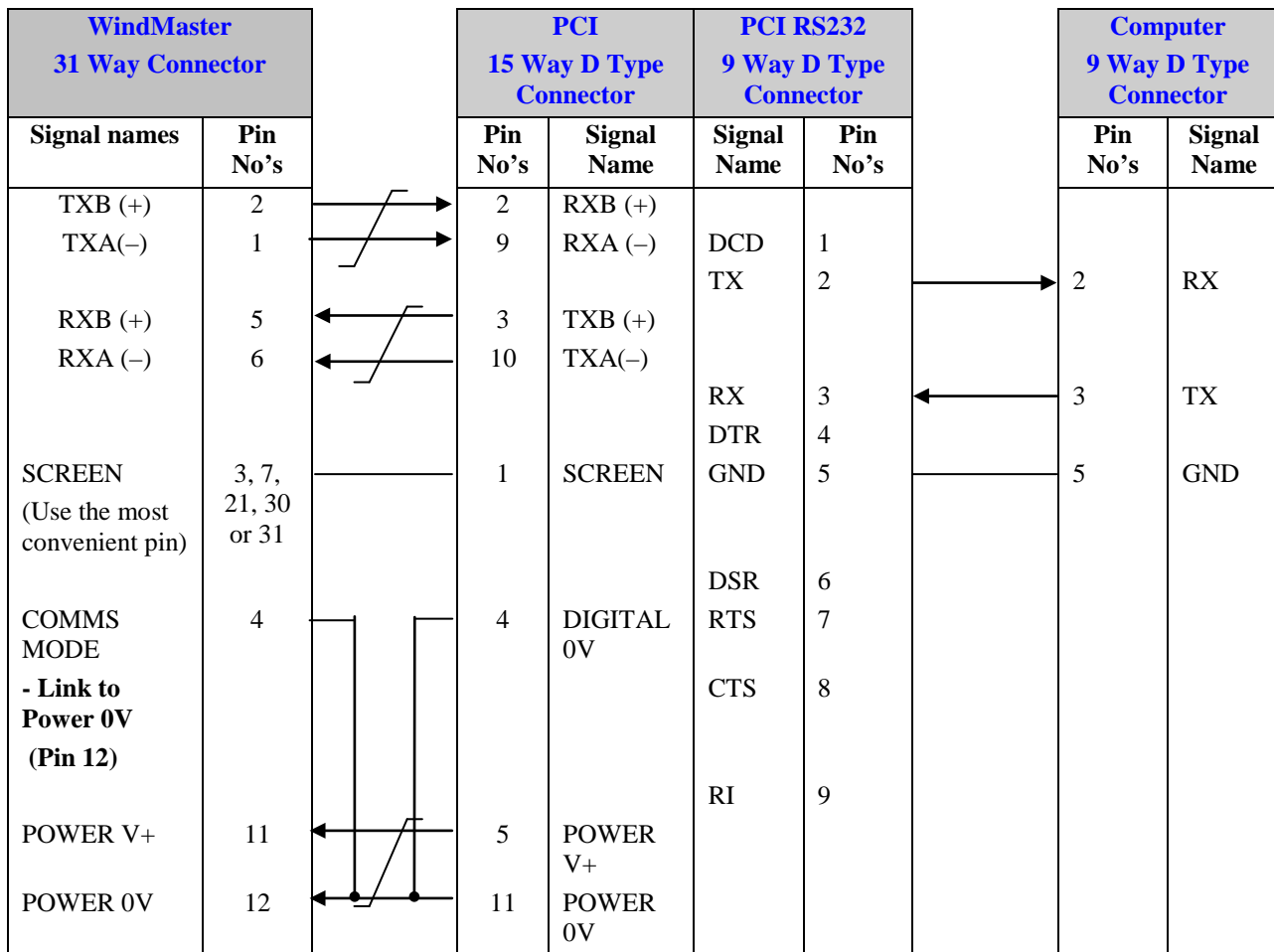

Environmental

The Desktop PCI is intended for use in a protected environment and provides interfacing to a single anemometer. RS232 and RS422 ports are provided. The PCI is not intended for outdoor use.

PCI Electrical Power Requirements

- 1) 100Vac - 120Vac, 10VA from a mains supply for the 115V switch position.
- 2) 200Vac - 250Vac, 10VA from a mains supply for the 230V switch position.
- 3) 9 - 30Vdc, 55mA from an external low voltage supply for the anemometer (excluding analogue outputs).
- 4) 8 - 15Vdc, 50mA max from an external low voltage supply for the interface box only.

3 fuses protect the unit:

1. Externally accessible 1 A (T) for 115/230v operation.
2. Internally accessible 500 mA (T) AUX.
3. Internally accessible 500 mA (T) ANEM.

PCI Operation.

There are three Red LED's on the PCI front panel.

When the PCI box is powered the Power LED will illuminate.

When a WindMaster/WindMaster Pro is connected as above to the PCI box and is set to output continuous data the PCI box RX LED will flash on/off at the WindMaster output rate thus giving a good indication that the WindMaster output is wired to the PCI box correctly and outputting RS422 data correctly.

If the PCI RS 232 connection is connected to a computer then when a terminal programme is opened and commands sent by a PC keypad or program to the PCI box its TX LED will illuminate intermittently indicating a good connection between the PC and PCI box.

Connector Pin and Cable Assignments for PCIA

| Anemometer Connector 15 - Way | |
|-------------------------------|---------------------------|
| Pin | Designation |
| 1 | Screen |
| 2 | RS422_RXB (+) |
| 3 | RS422_TXB (+) |
| 4 | Digital 0V, Signal ground |
| 5 | Supply V+ |
| 6 | Analogue output V1 |
| 7 | Not used |
| 8 | Analogue output V2 |
| 9 | RS422_RXA (-) |
| 10 | RS422_TXA (-) |
| 11 | Supply V- |
| 12 | Analogue output V4 |
| 13 | Analogue 0V |
| 14 | Not used |
| 15 | Analogue output V3 |

| External, DC Supply 4 - Way | |
|-----------------------------|--------------------|
| Pin | Designation |
| 1 | Interface Box V+ |
| 2 | Interface Box V- |
| 3 | Anemometer Only V- |
| 4 | Anemometer Only V+ |

| RS232 Output - 9 way | |
|----------------------|---------------|
| Pin | Designation |
| 1 | DCD |
| 2 | TX data |
| 3 | RX data |
| 4 | DTR |
| 5 | Signal Ground |
| 6 | DSR |
| 7 | RTS |
| 8 | CTS |
| 9 | RI |

| RS422/Network Input 9 Way | |
|---------------------------|---------------|
| Pin | Designation |
| 1 | Not connected |
| 2 | Not connected |
| 3 | Not connected |
| 4 | RS422_RXA (-) |
| 5 | Signal ground |
| 6 | RS422_TXA (-) |
| 7 | RS422_TXB (+) |
| 8 | RS422_RXB (+) |
| 9 | Earth |

External D.C. Supply

Amphenol C91A Screw Lock 4 Way Socket, e.g. T3301 001.

View looking at pins

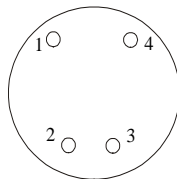

PCIA Box (1189-PK-020) WindMaster Analogue Output Connections.

If a PCIA box is available then a WindMaster with Analogue Output option connections can be routed from the 15 Way D type Input connector directly to the Auxiliary 9 way D type Output connector. (Note: The PCIA box does not convert the digital output from the WindMaster to analogue outputs).

| | WindMaster 31 -Way Clipper Connector | PCIA Box 15 – Way D Type Connector | PCIA Auxiliary or Sync Out 9 Way D Type Connector |
|-------------------|---|---------------------------------------|--|
| Function | Pin | Pin | Pin |
| Analogue Output 1 | 8 | 6 | 6 |
| Analogue Output 2 | 14 | 8 | 7 |
| Analogue Output 3 | 9 | 15 | 8 |
| Analogue Output 4 | 15 | 12 | 9 |
| Analogue Ground | 10, 16 or 17 | 13 | 2, 3, 4 and 5 (Grounds for Analogues 1 to 4 respectively) |

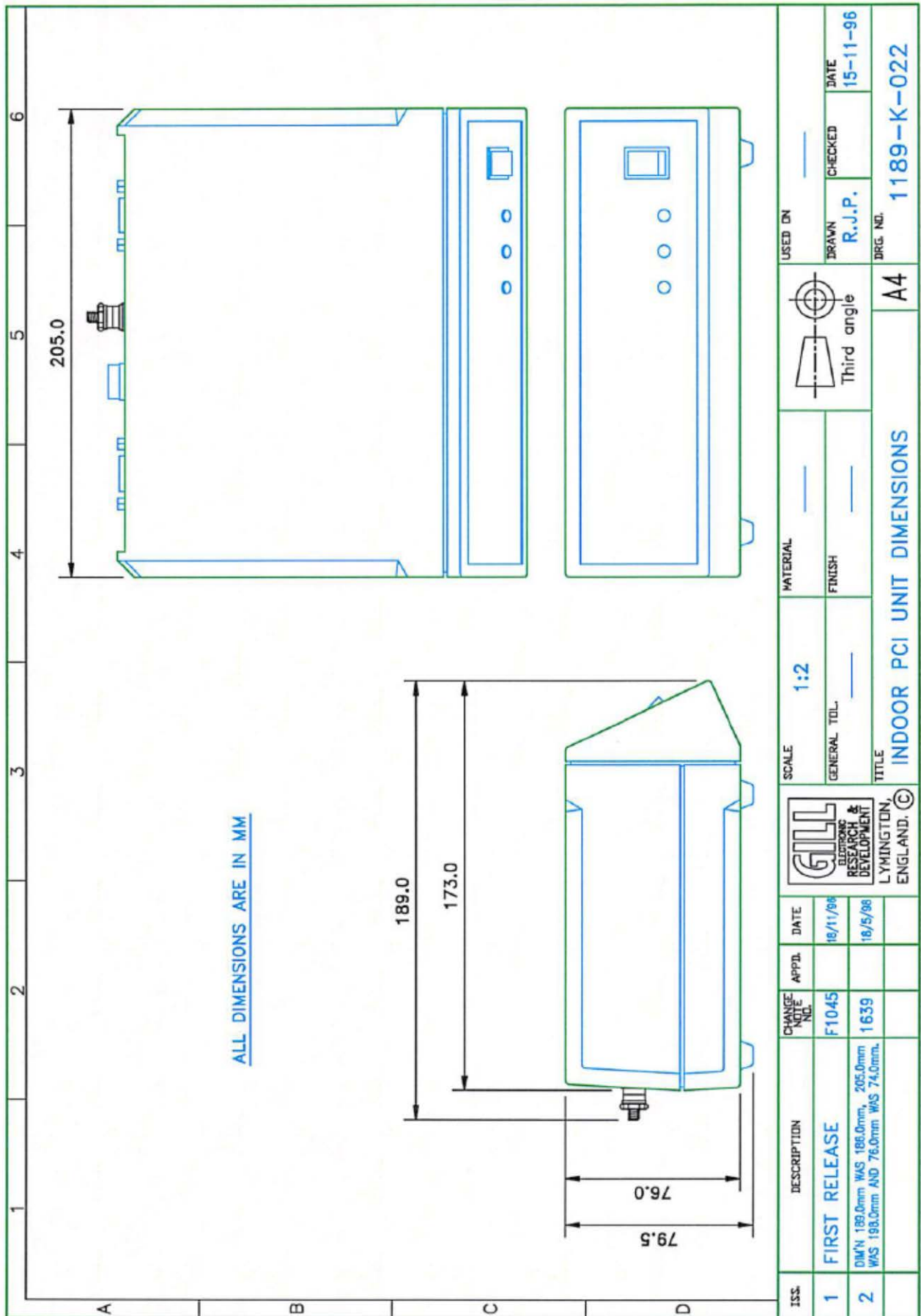

6.10. Using RS485, 2 Wire, WindMaster/WindMaster Pro Networking

Notes:-

1. These notes apply to using WindMasters and WindMaster Pro's only on a 2 wire RS485 network.
2. Set up the WindMaster operating configuration before wiring for RS485 mode.
3. WindMasters **must** be configured for RS485 by linking Comms Mode line (Pin 4) to 0V (Pin 12).
4. On Pipe Mount box units set J4 Link to COM/CM and externally link Comms mode to Power V+ or internally move link from J4 COM/CM to between COM and V+.
5. On non pipe mount box units if Pin 4 is left open circuit the unit will default to RS422 operation in Auto mode.
6. WindMasters **must** be in a Polled mode.
7. The baud rate setting may need to be adjusted/increased to 38400 or above depending on the poll rate.
8. The Master unit can be any suitable control device fitted with a RS485 interface card, such as a PC or Data logger. For best operation then the units should be connected directly to an RS485 interface card, use of some converters may degrade operation.
9. Analogue Outputs are also simultaneously available.
10. Node IDs of A-F, K, M, N or P are not recommended to use in a multi-drop system as these letters may appear in the WindMaster data string.
11. See Para 7.3 for more details on Poll operation.

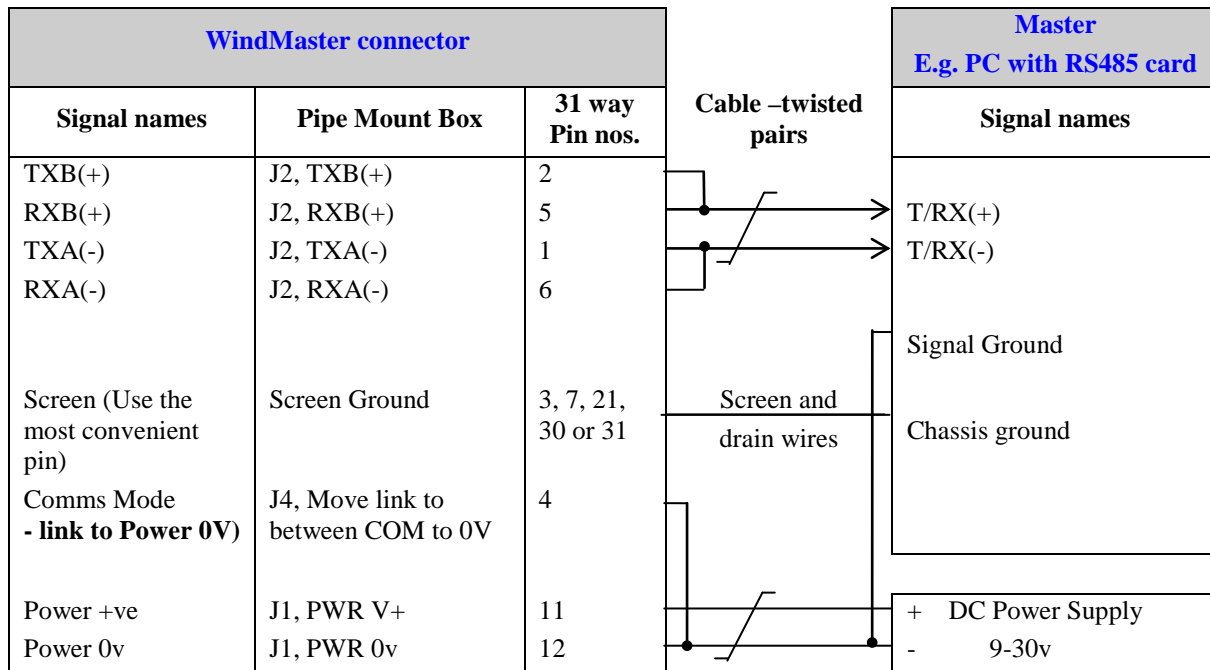

6.11. Mechanical installation

Before installing, it is strongly recommended that a bench test is carried out.

Location

Select a position so that the unit is clear of any structure, which may obstruct the airflow or induce turbulence.

Do NOT mount the WindMaster in close proximity of high-powered radar or radio transmitters. A site survey may be required if there is any doubt about the strength of external electrical noise.

Orientation

Normally the WindMaster/Pro is mounted vertically, ensuring a horizontal Measuring Plane.

However, the unit may be mounted with the Measurement Plane set to any required orientation, **provided** the sealing gasket is fitted to the flange and provision is made to seal the M4 base mounting nuts (i.e. with a rubber boot) to prevent water ingress. **It is particularly important for the WindMaster RA** to have the gasket fitted and use RTV sealant around the base when unit is connected up so as to prevent water penetration through cables/connectors or base screws etc. Care must also be taken to ensure that water cannot penetrate through the cable at any point and find a route through into the WindMaster connector.

Attention to sealing is especially if any model is to be used in an inverted position and it is advised to also use RTV sealant around the base when unit is connected up so as to prevent water penetration through cables/connectors or base screws etc.

Alignment and Dimensions

The reference north spar as indicated by a notch (that is in the direction line with north), which is also indicated on the base of the unit by another notch.

Figure 3 North Spar Alignment and Dimensions WindMaster Pro

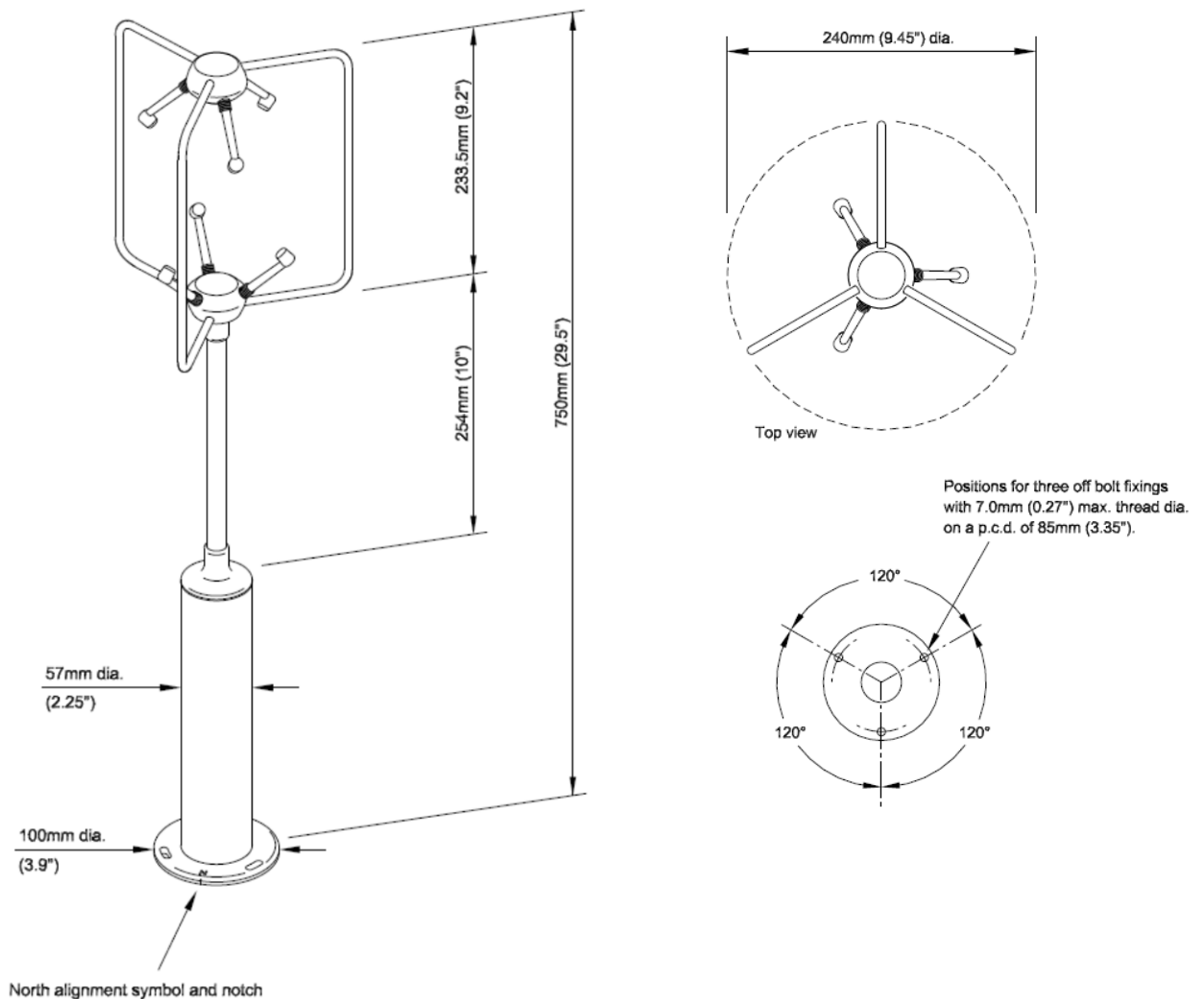

Part 1590-PK-130/W North Marker and WindMaster RA Dimensions

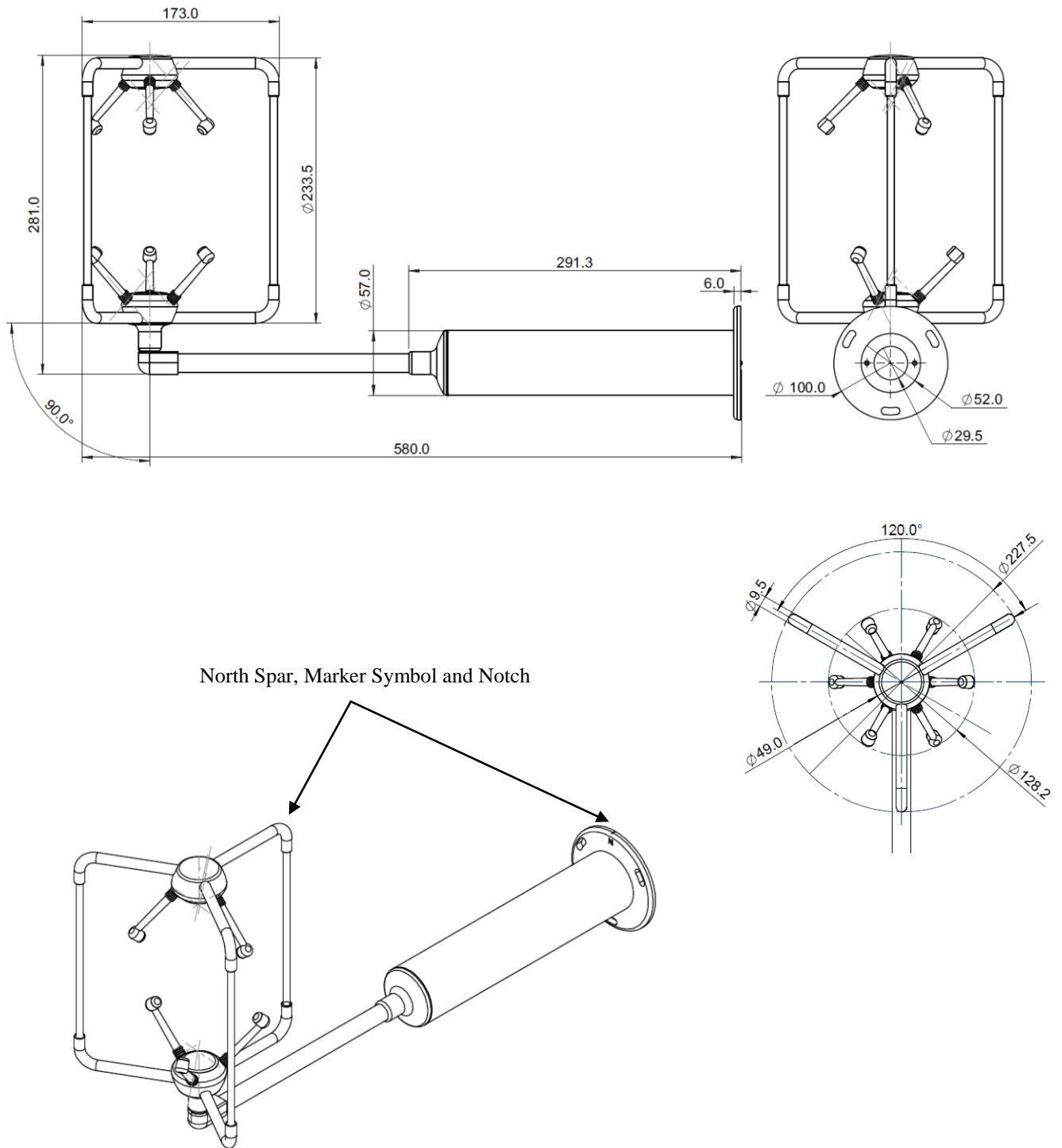

Part 1590-PK-050 WindMaster Pipe Mount Dimensions

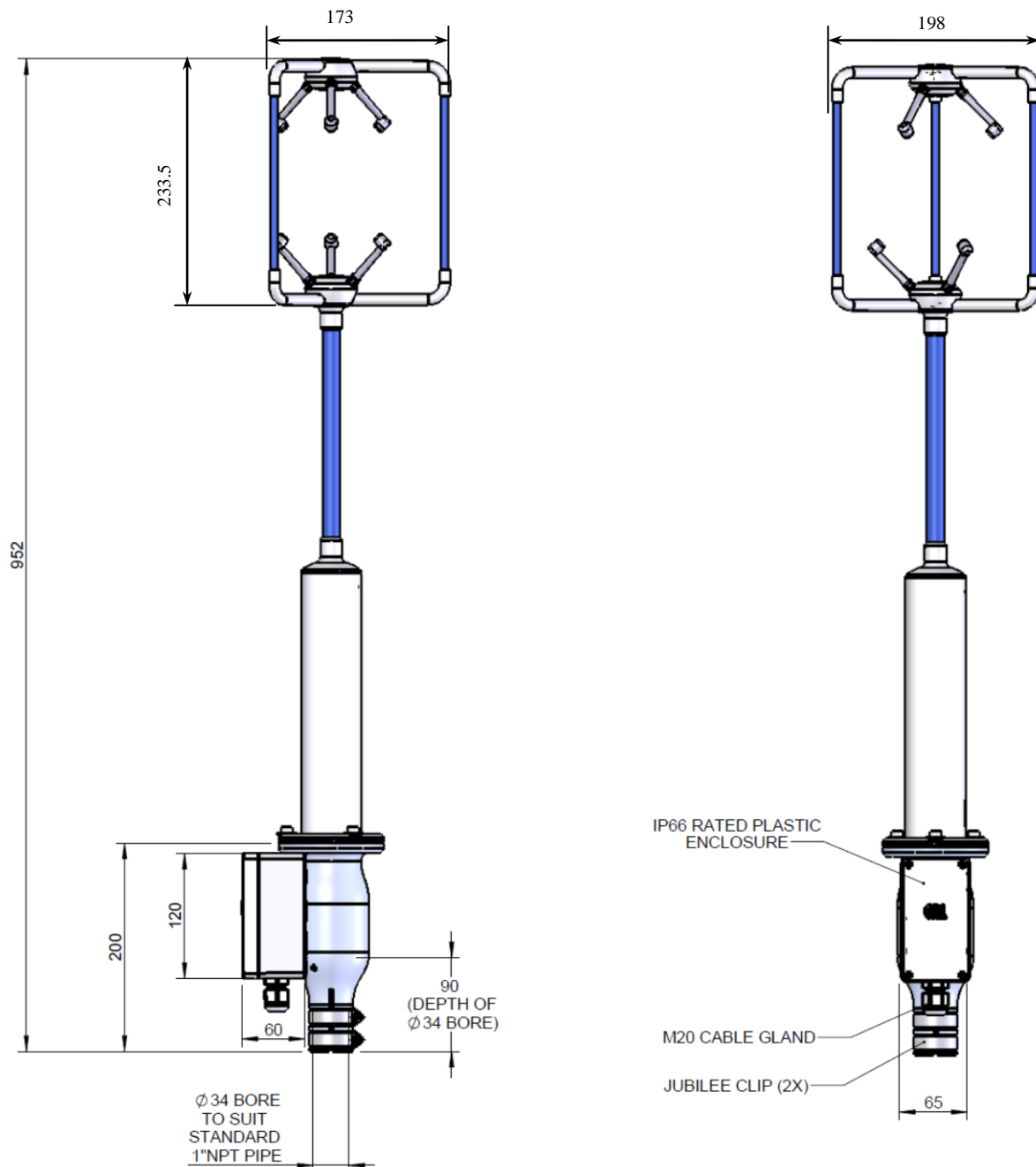

The North Spar and Alignment marking is illustrated in Figure 3 on the previous page.

Corrosion

Careful note should be taken of the possibility of galvanic corrosion by incorrect mounting. It is vital that only stainless steel fixings are used and that the instrument is insulated from the mounting surface with the rubber gasket. This will ensure that the anemometer will provide long service under extreme conditions such as marine.

Grounding (Earthing)

For protection against lightning the WindMaster **MUST** be earthed via its mountings.

The unit MUST be connected to an appropriate grounding point with a minimum of 6mm² copper wire.

Mounting WindMaster (1590-PK-020/W +options and WindMaster Pro (1561-PK-020/W + options).

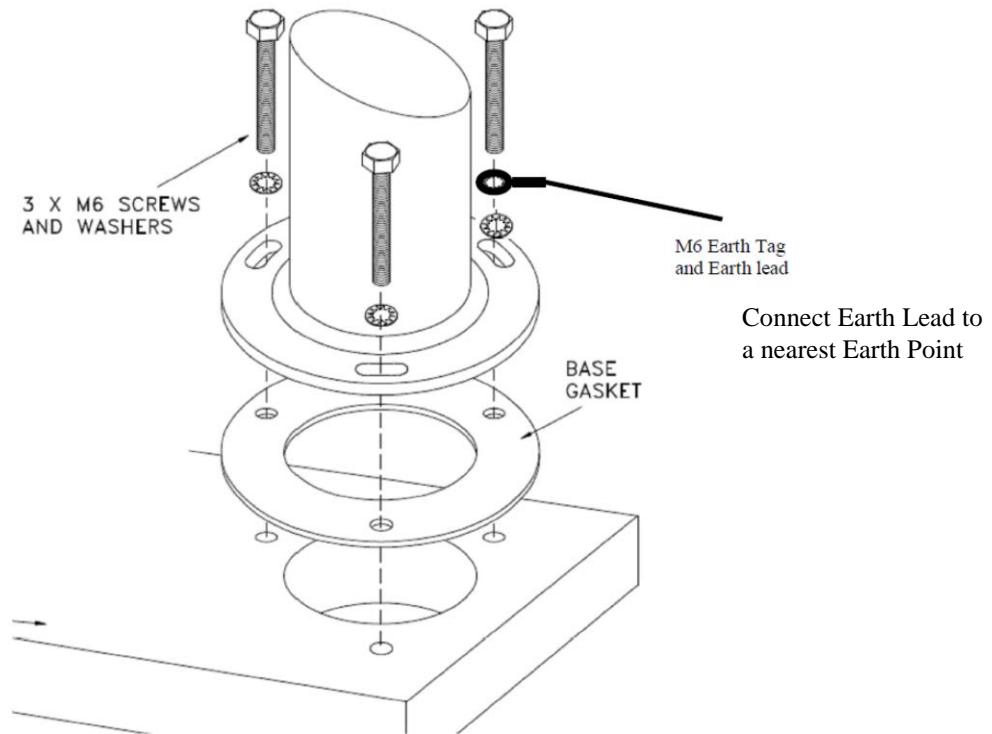

Cable strain relief

Fit strain relief when installing such that the weight of the cable is supported and does not put a strain on the connector.

Flange mounting

Mount the unit to a suitable surface, using the flange gasket and the M6 nuts, bolts and washers provided, ensuring that the clearance for the connector is maintained as shown on Figure 4.

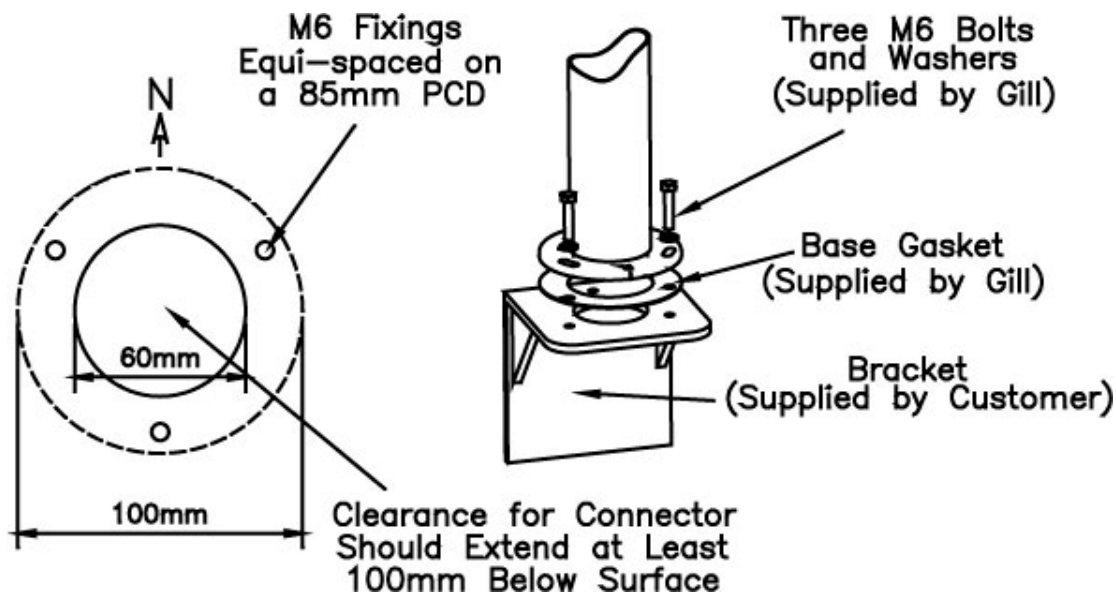

Figure 4 Flange Mounting

Gill Instruments Pipe mount adaptor (1561-PK-026).

The pipe mount adaptor enables the WindMaster to be fitted directly to a standard 1.5 inch BSP pipe (Pipe size OD 1.9" (48.3mm) , ID 1.5" (38.1mm) , wall thickness 0.2" (5.08mm). The pipe mount adaptor can be ordered from Gill.

The WindMaster connector must be connected to the WindMaster before the pipe mount adaptor is attached to the WindMaster. Pass the cable (fitted with the 31 way Clipper plug) through the tube. Connect the plug by twisting it whilst pushing it gently into the socket on the WindMaster. When it locates, twist the outer sleeve clockwise to connect and lock the plug.

Fix the pipe mount adaptor to the pipe using the 2 off M8 stainless steel screws provided.

Note: the customer **MUST** fit appropriate strain relief to the cable - this is particularly important with pipe mounting.

Mount the WindMaster unit to the pipe mount adaptor using the flange gasket and the M6 nuts, bolts and washers provided.

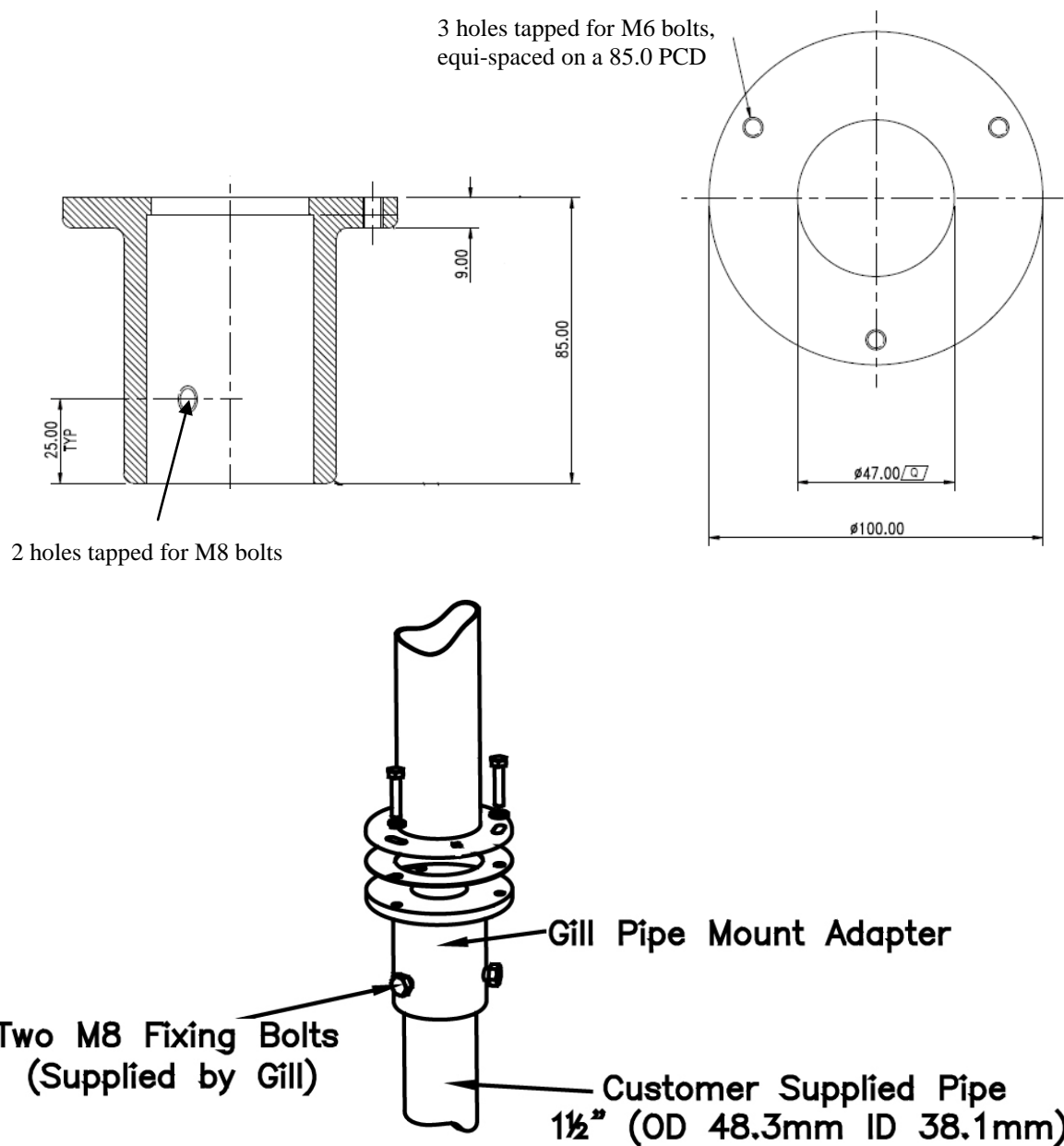

Figure 5 Pipe Mount Adaptor (1561-PK-026)

In whichever way the WindMaster is mounted ensure a good Earth connection is made. An earth connection can be made using a 6mm² wire see page 28.

Gill Instruments WindMaster 1590-PK-050 Pipe Mount Adaptor.

WindMaster Part 1590-PK-050 is supplied with a Pipe Mount pre-assembled to the base of the WindMaster and with an installation kit box (part 1590-PK-045) to complete mounting the assembled unit to a pipe.

The Pipe Mount has a smooth internal bore (3.54 inches/90mm in depth) and is designed to mount on a smooth pipe with a nominal outer diameter of 1.32 inches or 33.4mm. E.g. a pipe with outer dimensions of a one inch national pipe thread.

Assembly Details.

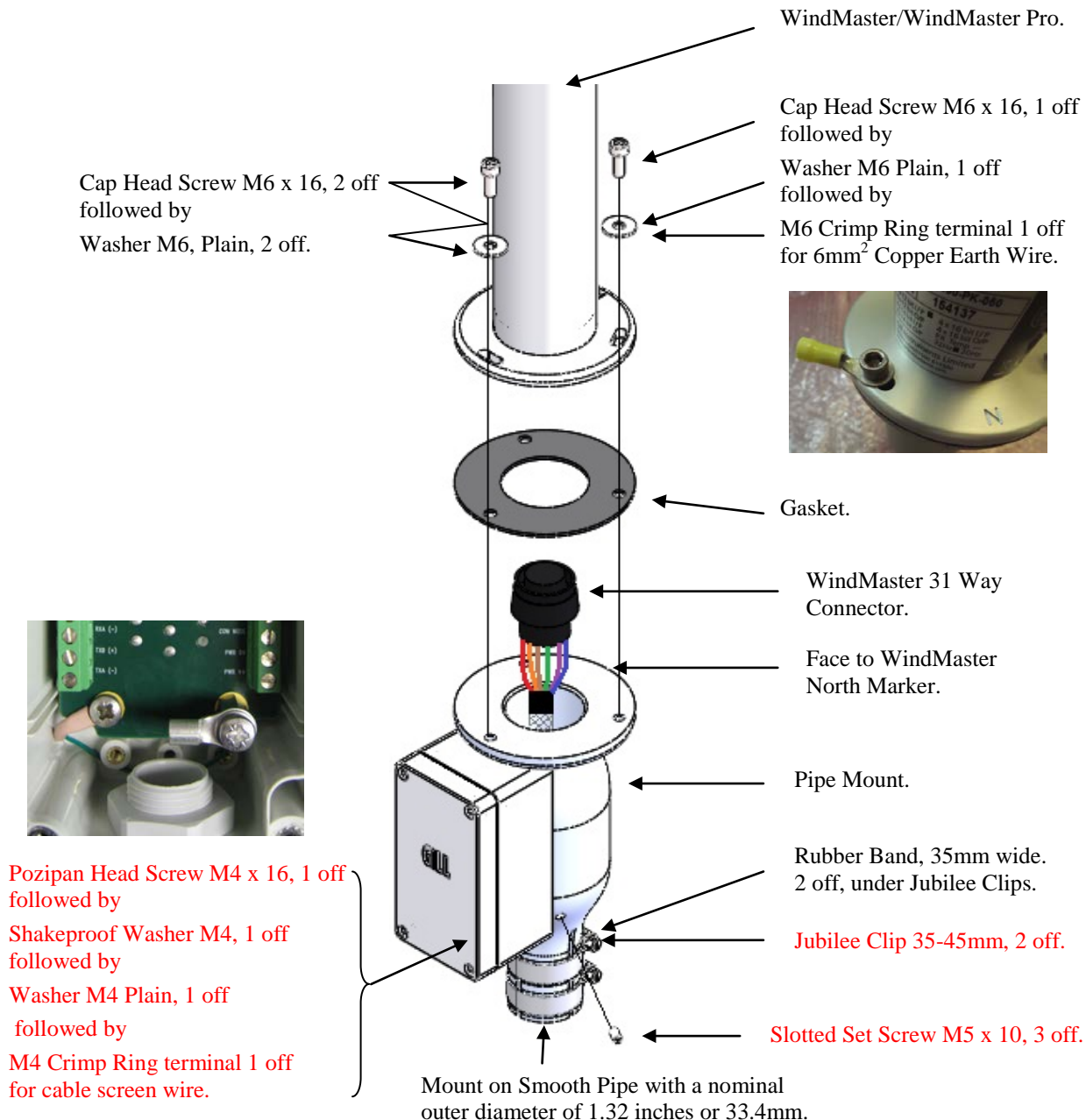

Mounting.

Open the supplied installation kit box 1590-PK-045 and referring to the above illustration.

Slide on the two supplied 35-45mm Jubilee Clips over the two rubber strips (see above illustration).

Slot the WindMaster into position on to the mounting pipe (engage to depth of 90mm).

Fit the 3 off M5 set screws into three equidistant holes in the pipe mount, see above illustration. Align the unit North Spar/N marking to North as required (see Page 27, Figure 3) and then tighten the 3 set screws in place.

Tighten and torque the two Jubilee clips in turn, evenly to a figure of 5 Newton/Metres or 45 Pounds/Inch.

Notes:

The M20 Cable gland from the connection box is designed to accept cables with an outer diameter between 8mm to 13mm.

Connect the external cable screen/s to the pillar inside the box using the supplied M4 parts illustrated above.

Appropriate strain relief **MUST** be fitted to the cable connected through the M20 cable gland - this is particularly important with pipe mounting.

Gill Instrument Pipe Mount Adaptor 1590-PK-048.

Gill Pipe Mount Adaptor Part 1590-PK-048 can be used with WindMaster and WindMaster Pro units.

A kit parts are supplied that can be assembled to the base of the WindMaster/Pro and to complete mounting the assembled unit to a pipe.

The Pipe Mount has a smooth internal bore (3.54 inches/90mm in depth) and is designed to mount on a smooth pipe with a nominal outer diameter of 1.32 inches or 33.4mm. E.g. a pipe with outer dimensions of a one inch national pipe thread.

Assembly Details.

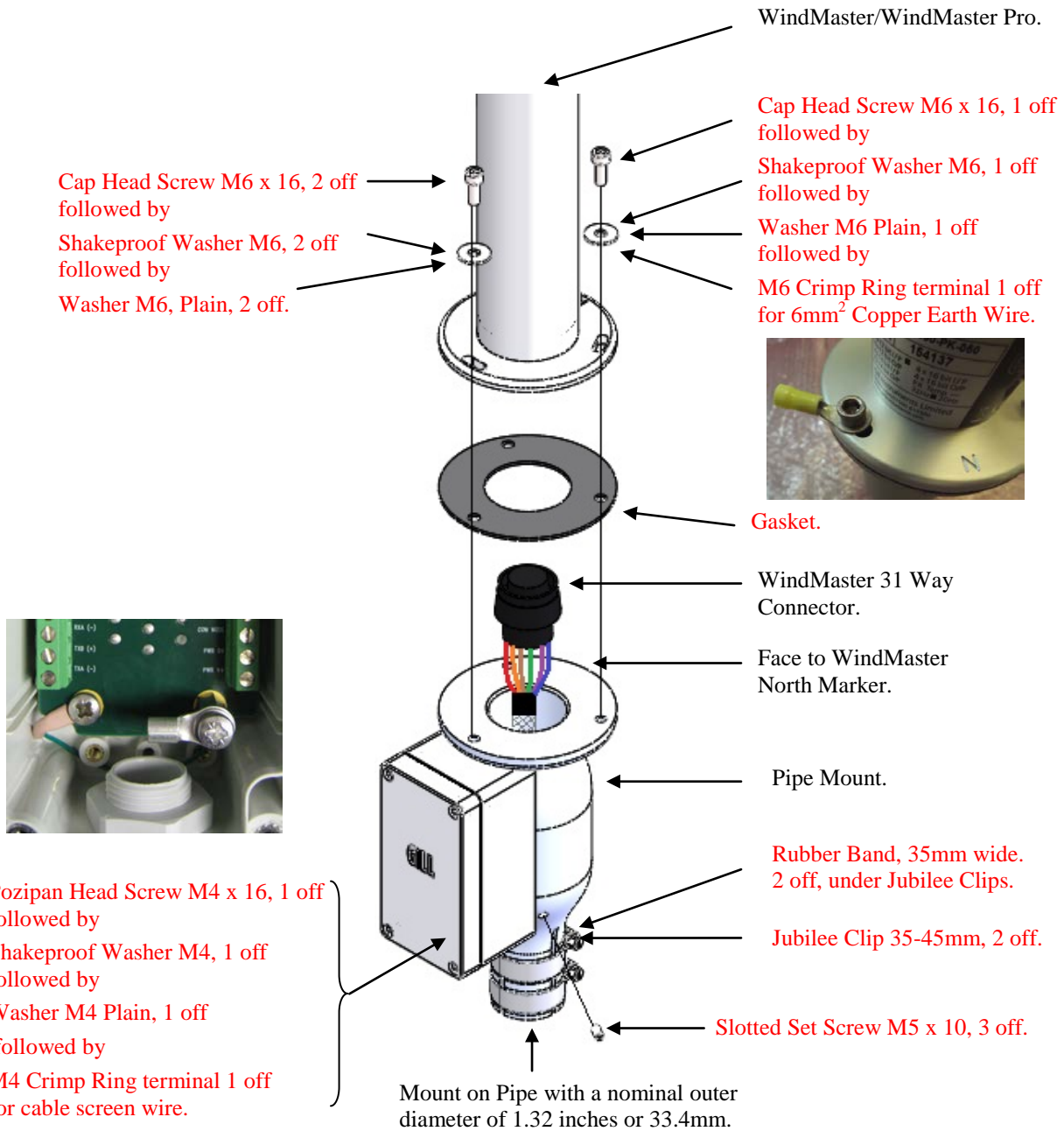

Open the supplied installation kit box 1590-PK-046 which contains items highlighted in red and referring to the above illustration.

Assemble the WindMaster/WindMaster Pro base to the Pipe Mount, fitting the 31 way plug, M6 parts and gasket supplied in the sequence and order shown in the above illustration.

Slide the two 35mm rubber bands on to the pipe section of the mount.

Slide on the two supplied 35-45mm Jubilee Clips over the two rubber strips (see above illustration).

Slot the WindMaster into position on to the mounting pipe (engage to depth of 90mm).

Fit the 3 off M5 set screws into three equidistant holes in the pipe mount, see above illustration. Align the unit North Spar/N marking to North as required (see Page 27, Figure 3) and then tighten the 3 set screws in place.

Tighten and torque the two Jubilee clips in turn, evenly to a figure of 5 Newton/Metres or 45 Pounds/Inch.

Notes:

The M20 Cable gland from the connection box is designed to accept cables with an outer diameter between 8mm to 13mm.

Connect the external cable screen/s to the pillar inside the box using the supplied M4 parts illustrated above.

Appropriate strain relief **MUST** be fitted to the cable connected through the M20 cable gland - this is particularly important with pipe mounting.

The weight of the Pipe Mount is approximately 1.12kg.

Grounding (Earthing)

For protection against lightning the WindMaster **MUST** be earthed via its mountings.

The unit MUST be connected to an appropriate grounding point with a minimum of 6mm² copper wire.

An M6 ring terminal is fitted to the WindMaster as illustrated above to which the 6mm² copper wire can be crimped attached for connection to a ground point.

7. MESSAGE FORMATS

On applying power to the WindMaster, it will automatically operate in the Measurement Mode and provide wind measurements in one of the following formats:

- Mode 1 – ASCII, UVW, Continuous
- Mode 2 – ASCII, Polar, Continuous (**default format**)
- Mode 3 – ASCII, UVW, Polled
- Mode 4 – ASCII, Polar, Polled
- Mode 7 – Binary, Polar, Short
- Mode 8 – Binary, UVW, Short
- Mode 9 – Binary, Polar, Long
- Mode 10 – Binary UVW, Long

Note: In this Section, the default settings are shown in **Bold**.

The user need not necessarily use a terminal emulator to store and analyse data being sent by the Anemometer. This section describes the modes and format of the data output to enable specific interfacing software to be generated by the user.

Information on how to change the formats and all the settings follows in Section 10 CONFIGURING.

7.1. Mode 1– ASCII, UVW, Continuous

(a) Mode 1, Normal Resolution (J1).

ASCII, UVW, Continuous, Speed of Sound On, Sonic Temp On, [Analogue inputs On], PRT On

In this mode, the wind speed outputs are given as signed (i.e. positive or negative) speeds along the U axis, V axis and the W (vertical) axis.

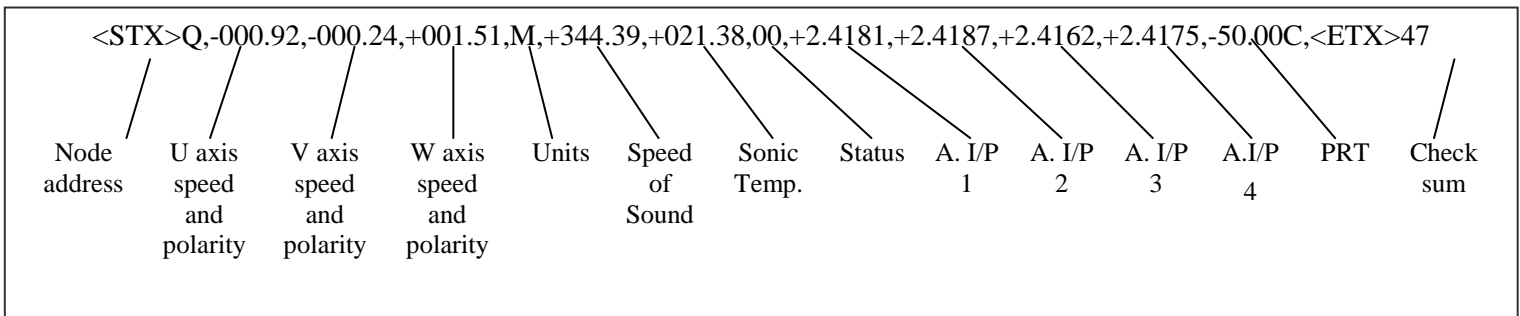

Format for software configuring is: -

<STX><ID>,±UUU.UU,±VVV.VV,±WWW.WW,U,±CCC.CC,±TTT.TT,SS,[±1.1111,±2.2222,±3.3333,±4.4444],±PP.PPC,<ETX>CC<CR><LF>

Where:

- <STX> - Start of string character (ASCII value 2)
- <ID> - Anemometer Identification (A-Z)
- ±UUU.UU - 'U' axis velocity 0.01ms⁻¹ units
- ±VVV.VV - 'V' axis velocity 0.01ms⁻¹ units
- ±WWW.WW - 'W' axis velocity 0.01ms⁻¹ units
- U - Units (M=m/s, N=knots, P=mph, K=kph)
- ±CCC.CC - Speed of Sound in 0.01ms⁻¹ units
- ±TTT.TT - Sonic Temperature in Degrees C.
- SS - Status data (Codes 00 to 0B)
- ±1.1111 - Analogue input 1 in volts
- ±2.2222 - Analogue input 2 in volts
- ±3.3333 - Analogue input 3 in volts
- ±4.4444 - Analogue input 4 in volts
- ±PP.PPC - PRT temperature in degrees C, e.g. +23.13deg C output as +23.13C in the string.
- <ETX> - End of string character (ASCII value 3)
- CC - Checksum of all Characters between <STX> and <ETX> (HEX byte)
- <CR><LF> - Carriage Return and Line Feed

<STX>

Start of string character (ASCII value 2).

WindMaster Identification node address

The default setting is 'Q'.

Horizontal wind speed

Shows the wind speed in the U / V Plane. *See Fig 2.*

Vertical wind speed

Shows the magnitude of wind speed in the W axis. *See Fig 2.*

Units

The Units identifier shows the units in which the wind speeds are measured.

| Units | Identifier |
|-----------------------------|------------|
| Metres per second (default) | M |
| Knots | N |
| Miles per hour | P |
| Kilometres per hour | K |
| Feet per minute | F |

Speed of Sound (SOS)

If enabled, this is displayed in metres per second.

Sonic temperature

If enabled, this is displayed in degrees C (*please note that this is not corrected for humidity*).

Status

This indicates either correct operation - Code 00 - or status code. *See 11.4 for explanation of codes.*

Analogue Inputs (Unit order option)

If enabled, the four Analogue inputs are an order option (see Para 8.1).

PRT (Unit order option)

If enabled, the Platinum Resistance Thermometer input is an order option (see Para 8.2).

Checksum

This enables the host system to check that the data has been correctly received. This is the EXCLUSIVE – OR of the bytes between (and not including) the <STX> and <ETX> characters reported as ASCII Hex.

<ETX>

End of string character (ASCII value 3).

Output rate (not displayed)

The WindMaster delivers wind information at rates from 1 (default setting) to 32 outputs / second.

[The sample rate (20 or 32 Hz) is chosen automatically to be an appropriate multiple of the output rate.]

Data can be instantaneous or averaged (see section 10).

NOTE use at least 38400 baud if high output rates 20/32Hz are used with all parameter outputs on.

(b) Mode 1 (High Resolution (J2))

ASCII, UVW, Continuous, Speed of Sound On, Sonic Temp On, [Analogue inputs On], PRT On

<STX><ID>,±UUU.UUU,±VVV.VVV,±WWW.WWW,U,±CCC.CC,±TTT.TT, SS,[±1.1111,±2.2222,±3.3333,±4.4444],±PP.PPC,<ETX>CC<CR><LF>

Where:

- <STX> - Start of string character (ASCII value 2)
- <ID> - Anemometer Identification (A-Z)
- ±UUU.UUU - 'U' axis velocity 0.001ms⁻¹ units
- ±VVV.VVV - 'V' axis velocity 0.001ms⁻¹ units
- ±WWW.WWW 'W' axis velocity 0.001ms⁻¹ units
- U - Units (M=m/s)
- ±CCC.CC - Speed of Sound in 0.01ms⁻¹ units
- ±TTT.TT - Sonic Temperature in Degrees C.
- SS - Status data (Codes 00 to 0B)
- ±1.1111 - Analogue input 1 in volts
- ±2.2222 - Analogue input 2 in volts
- ±3.3333 - Analogue input 3 in volts
- ±4.4444 - Analogue input 4 in volts
- ±PP.PPC - PRT temperature in degrees C, e.g. +23.13deg C output as +23.13C in the string.
- <ETX> - End of string character (ASCII value 3)
- CC - Checksum of all Characters between <STX> and <ETX> (HEX byte)
- <CR><LF> - Carriage Return and Line Feed

7.2. Mode 2 – ASCII, Polar, Continuous (Default Output Parameters in red)

(a) Mode 2 (Normal Resolution Shown J1)

ASCII, Polar+W, Continuous, Speed of Sound On, Sonic Temp On, [Analogue inputs On], PRT On

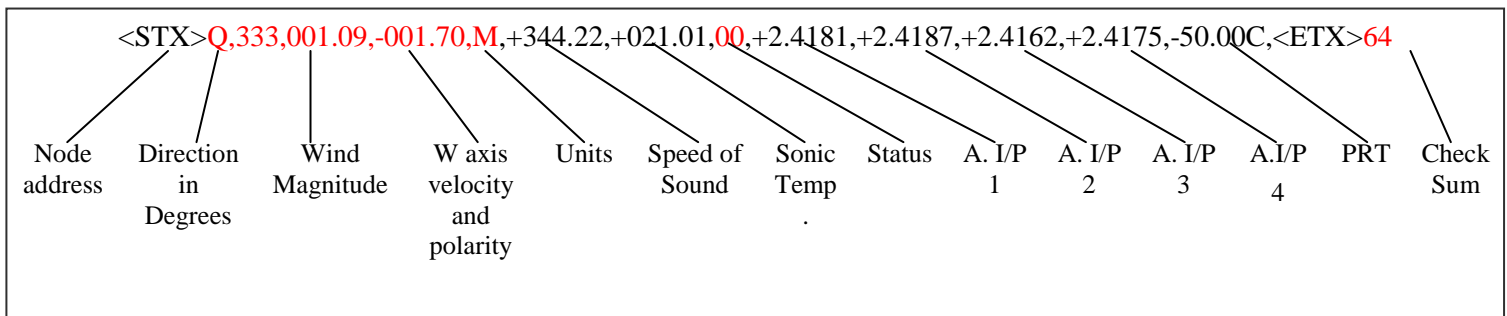

Format for software configuring is:-

<STX><ID>,DDD,MMM.MM,±WWW.WW,U,±CCC.CC,±TTT.TT,SS,[±1.1111,±2.2222,±3.3333±4.4444], ±PP.PPC,<ETX>CC<CR><LF>

Where:

- <STX> - Start of string character (ASCII value 2)
- <ID> - **Anemometer Identification (A-Z)**
- DDD** - **Direction in degrees**
- MMM.MM** - **Wind Magnitude**
- ±WWW.WW** - **'W' axis velocity 0.01ms⁻¹ units**
- U** - **Units (M=m/s, N=knots, P=mph, K=kph)**
- ±CCC.CC - Speed of Sound in 0.01ms⁻¹ units
- ±TTT.TT - Sonic Temperature in Degrees C.
- SS** - **Status data (Codes 00 to 0B)**
- ±1.1111 - Analogue input 1 in volts
- ±2.2222 - Analogue input 2 in volts
- ±3.3333 - Analogue input 3 in volts
- ±4.4444 - Analogue input 4 in volts
- ±PP.PPC - PRT temperature in degrees C, e.g. +23.13deg C output as +23.13C in the string.
- <ETX> - End of string character (ASCII value 3)
- CC** - **Checksum of all Characters between <STX> and <ETX> (HEX byte)**
- <CR><LF> - Carriage Return and Line Feed

Parameters are as described in Para 7.1 except that :-

Horizontal wind direction

Indicated in degrees, from 0 to 359°, with respect to the WindMaster North marker.

In fixed field mode and when the wind speed is below 0.05 metres/sec, the direction will not be calculated, but the last calculated direction above 0.05 m/s will be output (the threshold of 0.05 m/s is the default setting; it is user-configurable).

(b) Mode 2 (High Resolution Shown J2)

ASCII, Polar+W, Continuous, Speed of Sound On, Sonic Temp On, [Analogue inputs On], PRT On

```
<STX><ID>,DDD.D,MMM.MMM,±WWW.WWW,U,±CCC.CC,±TTT.TT,SS,[±1.1111,±2.2222,±3.3333
±4.4444],±PP.PPC,<ETX>CC<CR><LF>
```

Where:

| | | |
|----------|---|---|
| <STX> | - | Start of string character (ASCII value 2) |
| <ID> | - | Anemometer Identification (A-Z) |
| DDD.D | - | Direction in degrees |
| MMM.MMM | - | Wind Magnitude |
| ±WWW.WWW | - | 'W' axis velocity 0.001ms^{-1} units |
| U | - | Units (M=m/s) |
| ±CCC.CC | - | Speed of Sound in 0.01ms^{-1} units |
| ±TTT.TT | - | Sonic Temperature in Degrees C. |
| SS | - | Status data (Codes 00 to 0B) |
| ±1.1111 | - | Analogue input 1 in volts |
| ±2.2222 | - | Analogue input 2 in volts |
| ±3.3333 | - | Analogue input 3 in volts |
| ±4.4444 | - | Analogue input 4 in volts |
| ±PP.PPC | - | PRT temperature in degrees C, e.g. +23.13deg C output as +23.13C in the string. |
| <ETX> | - | End of string character (ASCII value 3) |
| CC | - | Checksum of all Characters between <STX> and <ETX> (HEX byte) |
| <CR><LF> | - | Carriage Return and Line Feed |

7.3. Mode 3—ASCII, UVW, Polled.

Mode 3 (Normal Resolution Shown)

ASCII, UVW, Polled, Speed of Sound On, Sonic Temp On, [Analogue inputs On], PRT On

```
<STX><ID>,±UUU.UU,±VVV.VV,±WWW.WW,U,±CCC.CC,
±TTT.TT,SS,[±1.1111,±2.2222,±3.3333±4.4444],±PP.PPC,<ETX>CC<CR><LF>
```

Where:

| | | |
|----------|---|---|
| <STX> | - | Start of string character (ASCII value 2) |
| <ID> | - | Anemometer Identification (A-Z) |
| ±UUU.UU | - | 'U' axis velocity 0.01ms^{-1} units |
| ±VVV.VV | - | 'V' axis velocity 0.01ms^{-1} units |
| ±WWW.WW | - | 'W' axis velocity 0.01ms^{-1} units |
| U | - | Units (M=m/s, N=knots, P=mph, K=kph) |
| ±CCC.CC | - | Speed of Sound in 0.01ms^{-1} units |
| ±TTT.TT | - | Sonic Temperature in Degrees C. |
| SS | - | Status data (Codes 00 to 0B) |
| ±1.1111 | - | Analogue input 1 in volts |
| ±2.2222 | - | Analogue input 2 in volts |
| ±3.3333 | - | Analogue input 3 in volts |
| ±4.4444 | - | Analogue input 4 in volts |
| ±PP.PPC | - | PRT temperature in degrees C, e.g. +23.13deg C output as +23.13C in the string. |
| <ETX> | - | End of string character (ASCII value 3) |
| CC | - | Checksum of all Characters between <STX> and <ETX> (HEX byte) |
| <CR><LF> | - | Carriage Return and Line Feed |

Polled Mode Notes General

The unit must be set for a polled Mode (M3 or M4).

When in the Polled mode, an output is only generated when the host system sends a Poll signal to the WindMaster consisting of the WindMaster Unit Identifier – that is, the relevant letter A – Z.

The default setting is 'Q'.

It is recommended that letters A to F, K, M, N, and P are not used since they can appear in a WindMaster data string and might result in erroneous poll responses.

The commands available in Polled Mode are:

| Description | Command | WindMaster Response |
|------------------------------------|------------|--|
| WindMaster Unit Identifier | A Z | Wind speed output generated |
| Enable Polled mode | ? | (none) |
| Disable Polled mode | ! | (none) |
| Request WindMaster Unit Identifier | & | A Z (as configured) |
| Enter Configuration mode | *<N> | CONFIGURATION MODE |
| Default Poll Mode | Syncpoll 0 | Ultrasonic firings take place in the background at the output rate. Data Output is asynchronous to the poll command. |
| Single Ultrasonic Firing Poll mode | Syncpoll 1 | A single ultrasonic firing result is output. It is triggered/synchronised to the poll command. |

* Where <N> is the Unit Identifier.

It is suggested that in polled mode the following sequence is used for every poll for information.

? Ensures that the Sensor is enabled to cover the event that a power down has occurred.

A-Z Appropriate unit designator sent to retrieve a line of data.

! Sent to disable poll mode and reduce possibility of erroneous poll generation.

If the unit is powered down after use or upon switch on then allow 5 seconds from switch on before sending poll commands.

When in polled mode the unit will respond to a poll data command within 30mS of receiving the command.

Maximum poll rate for all modes is 20Hz.

Syncpoll 0 Mode Notes (Default)

Default Syncpoll 0 is set up as follows: -

Open Wind Software.

Type * or *<N> (if already in a polled mode) to enter CONFIGURATION MODE.

Type Syncpoll 0 and press Enter (note there is a space between Syncpoll and 0).

Type Q and press Enter to go to SyncPoll 0 measurement mode.

To check the current syncpoll setting when in configuration mode type Syncpoll and press return. The unit will respond with 1 or 0.

Ultrasonic firings take place in the background.

Receipt of a poll command will trigger an asynchronous Wind measurement output resultant from the previous measurements.

The maximum Poll command rate is 20Hz for a single unit connected point to point.

RS485 Networking Examples.

Use of a PC with integrated RS485 PCI Card

In tests four WM/WMP were connected to a PC PCI card and using a single RS485 2-wire port. 1Hz and 5Hz data was collected from each sensor and the sensors were set at 57600 baud. Tests were also carried out at 10Hz where a small amount of data loss was observed, leading to 99% of data being collected.

Use of a Data Logger

Tests have shown that at least five WindMasters or WindMaster Pros can work with a datalogger using a single RS485 2-wire port allowing 1Hz data collection from each sensor. The Wind sensors were set to 38400 baud, contact Gill Instruments for further details if required.

NB: some converters can cause data loss. Where possible, connect directly to an RS485 port.

Syncpoll 1 Mode Notes

Syncpoll 1 is set up as follows:-

Open Wind Software.

Type * or *<N> (if already in a polled mode) to enter CONFIGURATION MODE.

Type Syncpoll 1 and press Enter (note there is a space between Syncpoll and 1).

Type Q and press Enter to go to SyncPoll 1 measurement mode.

To check the current Syncpoll setting when in configuration mode type Syncpoll and press return. The unit will respond with 1 or 0.

Receipt of poll command will trigger a single 50mS or 31.25mS ultrasonic measurement and at the same time will trigger a Wind measurement output resultant from the previous polled measurement.

The minimum Poll command rate is 20Hz.

Analogue inputs are not supported in Syncpoll 1 mode.

RS485 Networking Examples

Use of a PC with integrated RS485 PCI Card

In tests four WM/WMP were connected to a PC PCI card and using a single RS485 2-wire port 20Hz data was collected from each sensor. The sensors were set to 57600 baud.

Use of a Data Logger

In tests two sets of two WindMaster (or WindMaster Pro's) were connected to two individual RS485 2-wire ports on a data logger that allowed 20Hz data to be collected from all four sensors. The wind sensors were set to 57600 baud, contact Gill Instruments for further details if required.

7.4. Mode 4 –ASCII, Polar, Polled.

Mode 4 (Normal Resolution Shown)

ASCII, Polar+W, Polled, Speed of Sound On ,Sonic Temp On, [Analogue inputs On], PRT On

<STX><ID>,DDD,MMM.MM,±WWW.WW,U,±CCC.CC,±TTT.TT,SS,[±1.1111,±2.2222,±3.3333±4.4444],±PP.PPC,<ETX>CC<CR><LF>

Where:

| | | |
|----------|---|---|
| <STX> | - | Start of string character (ASCII value 2) |
| <ID> | - | Anemometer Identification (A-Z) |
| DDD | - | Direction in degrees |
| MMM.MM | - | Wind Magnitude |
| ±WWW.WW | - | 'W' axis velocity 0.01ms^{-1} units |
| U | - | Units (M=m/s, N=knots, P=mph, K=kph) |
| ±CCC.CC | - | Speed of Sound in 0.01ms^{-1} units |
| ±TTT.TT | - | Sonic Temperature in Degrees C. |
| SS | - | Status data (Codes 00 to 0B) |
| ±1.1111 | - | Analogue input 1 in volts |
| ±2.2222 | - | Analogue input 2 in volts |
| ±3.3333 | - | Analogue input 3 in volts |
| ±4.4444 | - | Analogue input 4 in volts |
| ±PP.PPC | - | PRT temperature in degrees C, e.g. +23.13deg C output as +23.13C in the string. |
| <ETX> | - | End of string character (ASCII value 3) |
| CC | - | Checksum of all Characters between <STX> and <ETX> (HEX byte) |
| <CR><LF> | - | Carriage Return and Line Feed |

See also Polled Notes above.

7.5. Mode 7 –Binary, Polar, Short

<B1><B1>STATUS,DIR,MAG,W,SOS,CHECKSUM

| | | |
|----------|---|------------------------------|
| <B1> | - | |
| <B1> | - | |
| STATUS | - | Status data (Codes 00 to 10) |
| DIR | | Wind Direction |
| MAG | | Wind Speed |
| W | | W axis velocity |
| SOS | | Speed of Sound in 0.01ms |
| CHECKSUM | | |

Notes:-

Data is 2 byte signed two's complement (except unsigned for SOS; 1 byte for checksum).

Velocities are normal resolution (0.01m/s).

Outputs that are disabled are padded with zero to give fixed size records.

A Gill Binary to ASCII Converter is available to download from <http://gillinstruments.com/main/software.html>

7.6. Mode 8 –Binary, UVW, Short

<B2><B2>STATUS,U,V,W,SOS,CHECKSUM

| | | |
|----------|---|--|
| <B2> | - | |
| <B2> | - | |
| STATUS | - | Status data (Codes 00 to 0B) |
| U | | U axis velocity |
| V | | V axis velocity |
| W | | W axis velocity |
| SOS | | Speed of Sound in 0.01ms^{-1} |
| CHECKSUM | | |

7.7. Mode 9 –Binary, Polar, Long

<B3><B3>STATUS,DIR,MAG,W,SOS,A1,A2,A3,A4,PRT,CHECKSUM
 <B3> -
 <B3> -
 STATUS - Status data (Codes 00 to 0B)
 DIR Wind Direction
 MAG Wind Speed
 W W axis velocity
 SOS Speed of Sound in 0.01ms^{-1}
 A1 Analogue input 1
 A2 Analogue input 2
 A3 Analogue input 3
 A4 Analogue input 4
 PRT Platinum Resistance Thermometer input
 CHECKSUM

7.8. Mode 10 –Binary, UVW, Long

One record consists of 23 Bytes:-

0xB4 0xB4 StaL StaH Wc1L Wc1H Wc2L Wc2H Wc3L Wc3H SoSL SoSH A1L A1H A2H A2L A3H A3L A4H A4L
 TPrtL TPrtH,Checksum

| Variable | Description | Byte |
|-----------|---|-------|
| 0xB4 0xB4 | Start message identifier (HEX B4 = decimal 180) | 1+2 |
| Sta | Status data (Information only on low byte (Codes 00 to 0B), high byte always zero). | 3+4 |
| Wc1 | U axis wind velocity (16 bit signed integer). | 5+6 |
| Wc2 | V axis wind velocity (16 bit signed integer) | 7+8 |
| Wc3 | W axis wind velocity (16 bit signed integer) | 9+10 |
| SoS | Speed of Sound in 0.01ms (16 bit signed integer) | 11+12 |
| A1 | Analogue input 1 (16 bit signed integer). | 13+14 |
| A2 | Analogue input 2 (16 bit signed integer). | 15+16 |
| A3 | Analogue input 3 (16 bit signed integer). | 17+18 |
| A4 | Analogue input 4 (16 bit signed integer). | 19+20 |
| TPrt | Temperature from PRT (16 bit signed integer). | 21+22 |
| Checksum | Checksum (exclusive OR of bytes between start of message identifier and checksum byte). | 23 |

SoS is always reported as Speed of Sound independent of A command setting.

TPrt is always reported independent from the V command setting.

A1 to A4 are always reported independent from the I command setting.

8. ANALOGUE INPUTS

Notes:- Options of four analogue inputs must be specified when ordering.

WindMaster Part 1590-PK-050 is supplied with four off 12 bit analogue inputs.

Use Gill Wind Software to enable Analogue inputs.

Information on how to change the formats and all the settings follows in Section 10, CONFIGURING.

Averaging (G command) does not apply to Analogue inputs. If the G command is set for example to G10, one reading every 10 seconds, then the last value displayed will be output until the 10 second point arrives and a new instantaneous (non averaged) reading will be output.

Analogue inputs are not supported in Syncpoll 1 mode.

8.1. Analogue Inputs

The input range is fixed at $\pm 5V$

For pin connections see 6.6.1 and 6.6.2 Connections.

The WindMaster can be configured for 4 single analogue inputs (31 way connector Pins 27, 28, 29 and 24 or on Pipe mount box A IN 1, A IN 2, A IN 3, and A IN 4) or 2 differential analogue inputs. 31 way connector Input 1 (Pins 27 and 28) and Input 2 (Pins 29 and 24) or Pipe Mount box Input 1 (A IN 1 and A IN 2) and Input 2 (A IN 3 and A IN 4).

| | |
|-------------------------|--------------------------------|
| Input range | - 5 V to + 5 V |
| Common mode input range | $\pm 5 V$ |
| Input impedance | 310 K ohm in series with 2.5 V |
| Resolution | 12, 14 bit (as installed) |

8.2. PRT input

Available on the WindMaster Pro only. (Must be specified when ordering).

The PRT input is designed to work with any 4 wire PRT that meets IEC60751.

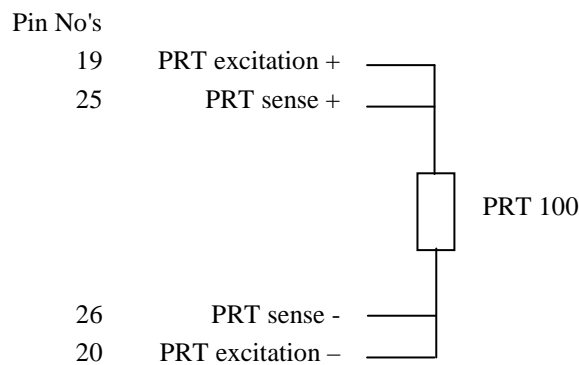

8.3. Input Rates

In single ended mode timing responses are:-

| Channel | 20Hz Base Rate | 32Hz Base Rate |
|---------|----------------|----------------|
| 1 | 20Hz | 32Hz |
| 2 | 20Hz | 16Hz |
| 3 | 5Hz | 4Hz |
| 4 | 5Hz | 4Hz |
| PRT | 5Hz | 4Hz |

9. ANALOGUE OUTPUTS

Notes: Options of four analogue outputs must be specified when ordering.

Use Gill Wind Software to enable Analogue outputs.

Information on how to change the formats and all the settings follows in Section 10, CONFIGURING.

Averaging (G command) does not apply to analogue outputs, these are updated at the unit base rate (20Hz or 32Hz).

Analogue outputs are always in Metres/Second irrespective of the digital output units setting.

If the M command is changed after setting up analogue outputs then note that Analogue settings may need to be re-configured for the new M setting.

9.1. Output allocations

Each of the outputs can be configured to one of the following;-

U, V, W, Polar Angle (Horizontal Direction), Speed of Sound, Sonic Temperature, Status, Polar magnitude (Horizontal Wind Speed).

9.2. Output types

They are user-configurable as:-

| | | | |
|---------|-----------|--------------------|----------------|
| Voltage | 0V to 5V, | or -2.5V to +2.5V, | or -5V to +5V, |
| Current | 4 -20 mA, | or 0 - 20mA. | |

9.3. Voltage outputs

The output impedance is less than 1 ohm. To prevent inaccuracies, the outputs should be connected to an input with an impedance greater than 10KΩ.

9.4. Current outputs

Important

When using the current outputs, the load resistance between the Output and Ground must be ≤ 300 ohms, including cable resistance.

This is to ensure that the voltage levels on the Analogue outputs do not exceed 5V.

9.5. Scaling (metres/second only)

This is user-configurable to 5, 10, 20, 30, 40, 50, 60, or 120 m/s full scale for wind speed.

Using 50m/s and UVW setting as an example, this defines the outputs range as follows

Polar setting will range between 0 – 50m/s.

| Output | Voltage 0 to 5V | Voltage ± 2.5V | Voltage ± 5V | Current 4 - 20 mA | Current 0 - 20 mA |
|---------|--------------------|-------------------|-----------------|----------------------|----------------------|
| U, V, W | | | | | |
| -50 m/s | 0 | -2.5 | -5 | 4 | 0 |
| 0 m/s | +2.5 | 0 | 0 | 12 | 10 |
| +50 m/s | +5 | +2.5 | +5 | 20 | 20 |

9.6. Polar wind direction wraparound

The wind direction in Polar mode can be configured for either 360° or 540° Wraparound. If the 360° mode is used with a chart recorder, large swings of the recorder pen will be experienced each time the wind direction passes between 0 and 359°. Using the 540° mode, when the wind first changes from 0° to 359°, there will be a step change on the output, but after this first time the output will change smoothly each time the wind passes through 360°. (Similarly, the first time the wind veers from 539° to 180°, there will be a step change, after which the output will change smoothly).

NOTE: Values given for guidance, considering a clockwise spin in Wind Direction

| Output | Voltage 0 to 5V | Voltage ± 2.5V | Voltage ± 5.0V | Current 4 - 20 mA | Current 0 - 20 mA |
|------------------------|--------------------|-------------------|-------------------|----------------------|----------------------|
| 360° | | | | | |
| 0° | 0.00 | - 2.50 | -5.0 | 4.00 | 0.00 |
| 180° | 2.50 | 0.00 | 0 | 12.00 | 10.00 |
| 359.9° | 5.00 | +2.50 | +5.0 | 20.00 | 20.00 |
| 540° wraparound | | | | | |
| 0° | 0.00 | -2.50 | -5.0 | 4.00 | 0.00 |
| 180° | 1.67 | -0.83 | -1.66 | 9.33 | 6.67 |
| 360° | 3.33 | +0.83 | +1.66 | 14.67 | 13.33 |
| 539.9° | 5.00 | +2.50 | +5.0 | 20.00 | 20.00 |

9.7. Speed of Sound and Sonic Temperature

Scaling for Speed of Sound and Sonic Temperature (Instrument Software version 2329-110 onwards) is as follows:-

| Sonic Temp (Deg C) | -40 | -30 | -20 | -10 | 0 | 10 | 20 | 30 | 40 | 50 | 60 | 70 |
|-----------------------|---------------|---------------|---------------|---------------|---------------|---------------|---------------|---------------|---------------|---------------|---------------|---------------|
| SOS (m/s) | 300.00 | 306.36 | 312.73 | 319.09 | 325.45 | 331.82 | 338.18 | 344.55 | 350.91 | 357.27 | 363.64 | 370.00 |
| +/-5V | -5.00 | -4.09 | -3.18 | -2.27 | -1.36 | -0.45 | 0.45 | 1.36 | 2.27 | 3.18 | 4.09 | 5.00 |
| 0-5V | 0.00 | 0.45 | 0.91 | 1.36 | 1.82 | 2.27 | 2.73 | 3.18 | 3.64 | 4.09 | 4.55 | 5.00 |
| +/-2.5 | -2.50 | -2.05 | -1.59 | -1.14 | -0.68 | -0.23 | 0.23 | 0.68 | 1.14 | 1.59 | 2.05 | 2.50 |
| 4-20mA | 4.00 | 5.45 | 6.91 | 8.36 | 9.82 | 11.27 | 12.73 | 14.18 | 15.64 | 17.09 | 18.55 | 20.00 |
| 0-20mA | 0.00 | 1.82 | 3.64 | 5.45 | 7.27 | 9.09 | 10.91 | 12.73 | 14.55 | 16.36 | 18.18 | 20.00 |

9.8. Status

If an output is configured for Status reporting (using Gill Wind Software) then example levels will be as follows for good signal high, bad (error) signal low depending on output type. High/Low table contents will be reversed if good signal low, bad signal high is used.

| | | | | | |
|--------------------------------|-----|-------|-----|------|------|
| Good Signal status code (high) | +5V | +2.5V | +5v | 20mA | 20mA |
| Error Signal Status Code (low) | 0V | -2.5V | -5V | 0mA | 4mA |

Note:-

Under a fault condition (status code not 00) analogue output wind readings will hold the last known good analogue value until the status fault changes back to 00, However Speed of Sound and Sonic Temperature will read full scale.

9.9. Default Output

If a unit has analogue outputs then the factory settings are:-

| | |
|-----------|--|
| Channel 1 | 0-5v, Polar Wind Angle, 0-360 degrees. |
| Channel 2 | 0-5v, Polar Wind Speed, 0-5m/s. |
| Channel 3 | 0-5v, W Wind Speed, 0-5m/s. |
| Channel 4 | 0-5v, Status. |

10. CONFIGURING AND VIEWING DATA

It is strongly recommended that **WIND** software (available free from the Gill website www.gillinstruments.com) is used to configure the WindMaster.

A less preferred option for configuring is using a terminal emulation package, using command codes.

These are both described in the sections below.

Note Certain combinations of output rate, baud rate and message type may be unsupported.

10.1. Configuring with Gill WIND software

Download the **WIND** software from the Gill website www.gillinstruments.com.

Assuming the WindMaster has been correctly connected to the PC and a Power Supply, the opening menu will show the WindMaster in Measurement mode. A short Start message will be displayed, followed by continuous wind information displayed - the default setting being **Polar**, with the unit of measure **Metres per second** (m/s).

If a message similar to the one below is displayed, click **Tools** and **Synch Comms** in the tool bar and the system will be synchronised and correct data displayed.

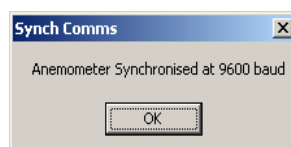
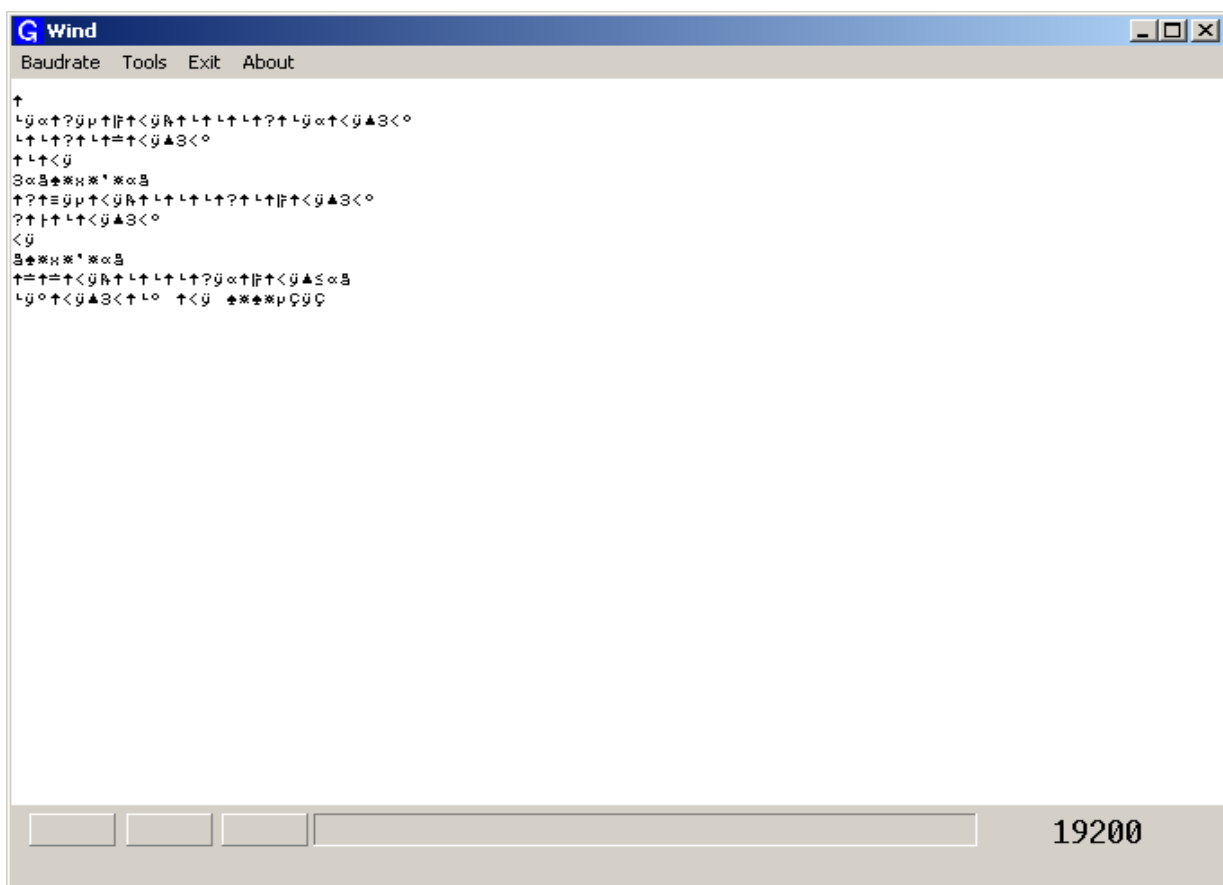

If after Synch Comms there is still a problem with start-up, switch power to anemometer off and then on again and repeat procedure.

The unit is set to factory default 1 Hz output and in Polar mode. A typical message format after Synchronising Comms is shown below:

```
WindMaster Pro 32Hz (SS) Gill Instruments Ltd
2329-110
RS232 (AUTO)
CHECKSUM ROM:9B50 9B50 *PASS*
CHECKSUM FAC:07BC 07BC *PASS*
CHECKSUM ENG:1E58 1E58 *PASS*
CHECKSUM CAL:3891 3891 *PASS*

00,061,000.12,+000.06,M,+345.83,+023.77,00,*0D
00,061,000.14,+000.05,M,+345.87,+023.83,00,*07
00,064,000.13,+000.05,M,+345.87,+023.83,00,*05
00,065,000.12,+000.06,M,+345.89,+023.87,00,*0C
00,062,000.13,+000.06,M,+345.83,+023.77,00,*0F
00,067,000.13,+000.06,M,+345.86,+023.82,00,*05
00,067,000.15,+000.05,M,+345.89,+023.87,00,*0A
00,068,000.13,+000.05,M,+345.78,+023.68,00,*0C
00,073,000.13,+000.06,M,+345.84,+023.78,00,*07
```

If you need to review your instrument settings click **Tools** and **Report config** in the tool bar. When selected a similar message to that below will be displayed.

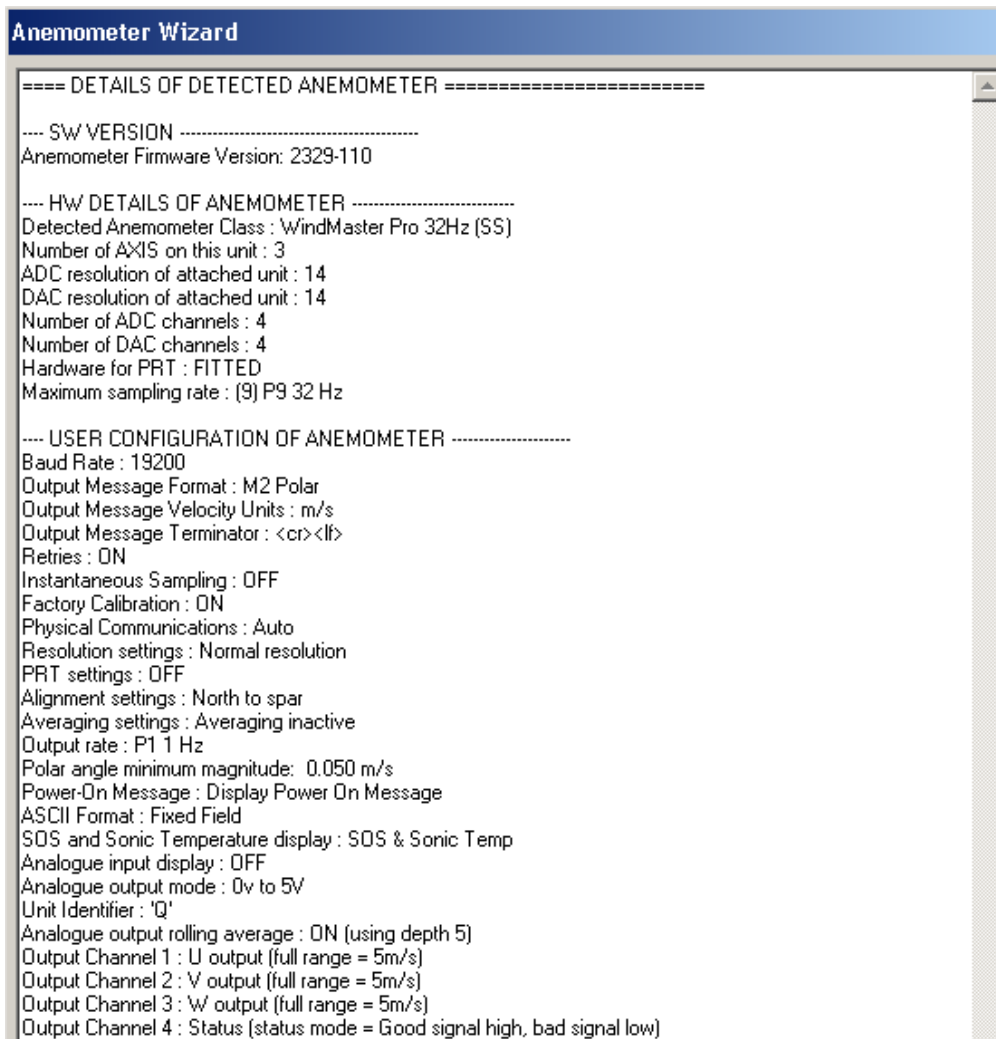

```
Anemometer Wizard
==== DETAILS OF DETECTED ANEMOMETER =====
---- SW VERSION -----
Anemometer Firmware Version: 2329-110

---- HW DETAILS OF ANEMOMETER -----
Detected Anemometer Class : WindMaster Pro 32Hz (SS)
Number of AXIS on this unit : 3
ADC resolution of attached unit : 14
DAC resolution of attached unit : 14
Number of ADC channels : 4
Number of DAC channels : 4
Hardware for PRT : FITTED
Maximum sampling rate : (9) P9 32 Hz

---- USER CONFIGURATION OF ANEMOMETER -----
Baud Rate : 19200
Output Message Format : M2 Polar
Output Message Velocity Units : m/s
Output Message Terminator : <cr><lf>
Retries : ON
Instantaneous Sampling : OFF
Factory Calibration : ON
Physical Communications : Auto
Resolution settings : Normal resolution
PRT settings : OFF
Alignment settings : North to spar
Averaging settings : Averaging inactive
Output rate : P1 1 Hz
Polar angle minimum magnitude: 0.050 m/s
Power-On Message : Display Power On Message
ASCII Format : Fixed Field
SOS and Sonic Temperature display : SOS & Sonic Temp
Analogue input display : OFF
Analogue output mode : 0v to 5V
Unit Identifier : 'Q'
Analogue output rolling average : ON (using depth 5)
Output Channel 1 : U output (full range = 5m/s)
Output Channel 2 : V output (full range = 5m/s)
Output Channel 3 : W output (full range = 5m/s)
Output Channel 4 : Status (status mode = Good signal high, bad signal low)
```

To change the WindMaster configuration click **Tools** and **Wizard** in the tool bar

Typical screens are shown below. The Customer is able to adjust all the settings as required taking into account the options selected at time of order (e.g. Analogue inputs and PRT).

Anemometer Wizard

| | |
|-----------------------|----------|
| Message Output Format | M2 Polar |
| Baud Rate | 19200 |
| Output Rate | P1 1 Hz |
| Message Terminator | <cr><lf> |
| Measurement Units | m/s |

| | |
|------------------------------|-------------------|
| Alignment | North to spar |
| Averaging (0 = Off) | 0 |
| Resolution | Normal resolution |
| Minimum direction Resolution | 50 |

Anemometer Wizard

| | |
|-------------------------|------------------|
| SOS/Sonic Temp Display | SOS & Sonic Temp |
| Display Analogue Inputs | OFF |
| Analogue Output Mode | 0v to 5V |
| PRT setting | OFF |

| | |
|------------------|---|
| Unit Identifier | Q |
| Power on Message | Display Power On Message |
| | <input checked="" type="checkbox"/> Retries Enabled |
| | <input type="checkbox"/> Instantaneous Sampling |
| | <input checked="" type="checkbox"/> Calibration Enabled |
| ASCII Format | Fixed Field |

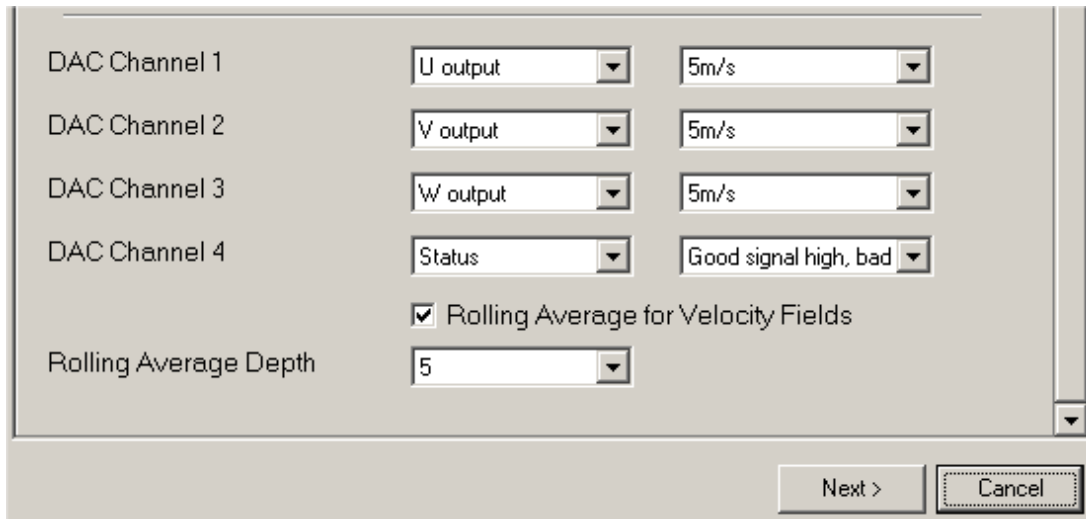

When the changes are complete the Wizard will display a confirmation of the changes with all changes shown in red, this may be printed as a hard copy if required. Click next and the WindMaster will be re-configured and will return to measurement mode.

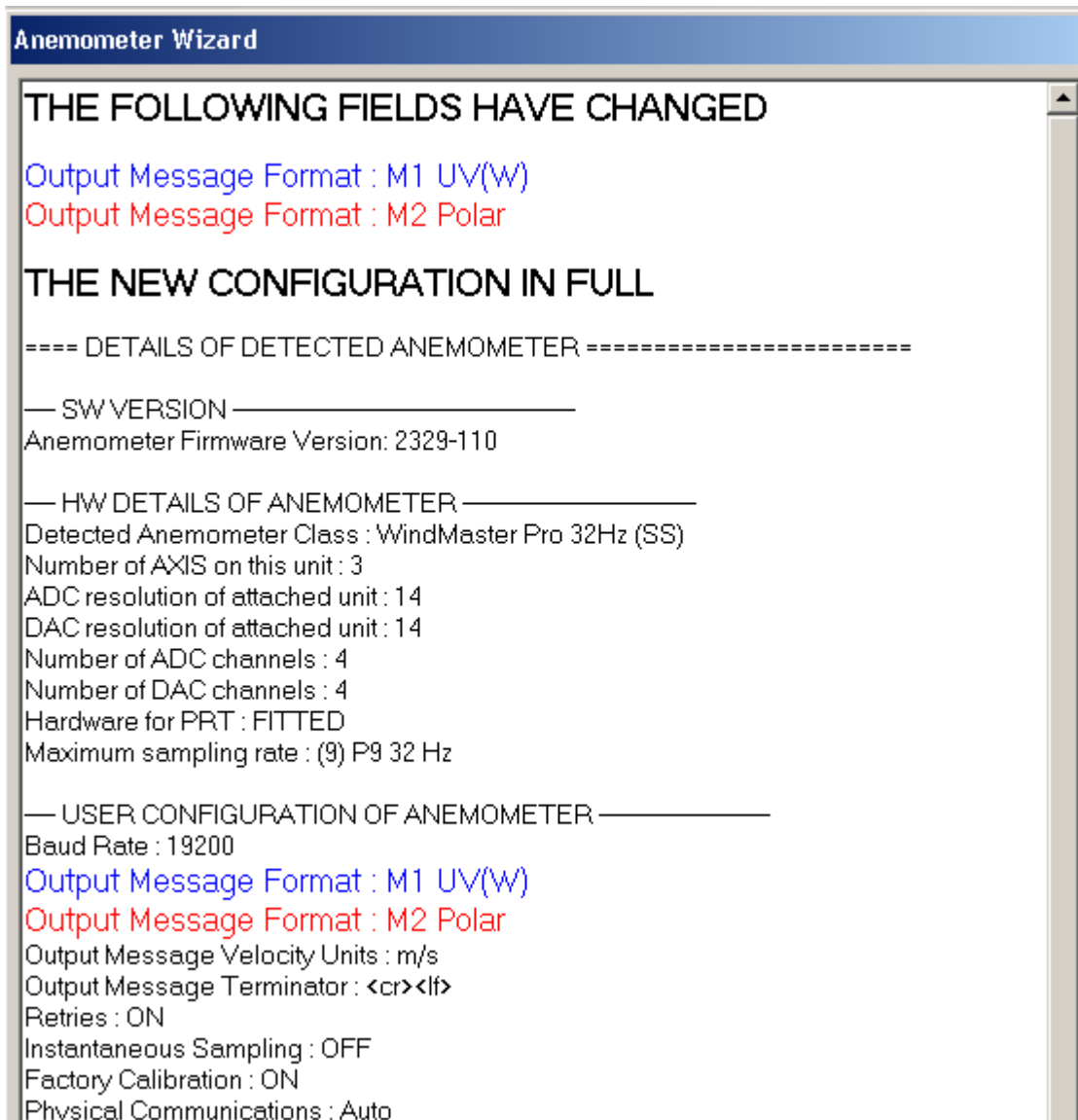

10.2. Configuring WindMaster using a Terminal Program e.g. HyperTerminal.

Note – Other terminal emulators can be used to configure the WindMaster in a very similar way.

Setting up

1. Decide on an available Com port that you want to use.
2. Run Hyperterm.exe (Typically accessed via Start → Programs → Accessories → Communications → Hyperterminal)
3. Create a New Connection (File → New Connection)
4. Enter a Name (eg WindMaster).
5. Change 'Connect Using' to 'Direct to Com 1' (or other Com port as required)
6. Adjust the Port settings to match WindMaster settings. WindMaster default settings are :

| | | |
|------------------------------|--|--------------------|
| Bits per second 19200 | Data bits 8 | Parity None |
| Stop bits 1 | Flow Control (Handshaking) None | |

Assuming the WindMaster has been correctly connected to the PC and a Power Supply, the opening menu will show the WindMaster in **Measurement mode** and scroll continuous wind information data.

Entering Configuration mode

From Continuous mode

From Polled mode

where N is the Unit identifier (a letter between A and Z)

The WindMaster responds with a CONFIGURATION MODE message, stops reporting wind measurements, and waits for a command (as detailed below).

Returning to Measurement mode

The WindMaster responds with wind measurements immediately when in Continuous mode, or on receipt of a Poll signal when in Polled mode.

This will be followed by a checksum test and then continuous wind information is displayed in the example as follows (polar, continuous, all options on).

RS232 (AUTO)

```
CHECKSUM ROM:102D 102D *PASS*
CHECKSUM FAC:0947 0947 *PASS*
CHECKSUM ENG:1E0B 1E0B *PASS*
CHECKSUM CAL:3891 3891 *PASS*
```

```
00, 118.1, 000.384, -000.992, M, +344.91, +022.19, 00, +2.4181, +2.4187, +2.4162, +2.4175, -50.00C, *71
00, 083.7, 000.686, -001.240, M, +345.96, +023.99, 00, +2.4181, +2.4187, +2.4162, +2.4175, -50.00C, *79
00, 086.4, 000.743, -001.273, M, +346.02, +024.09, 00, +2.4181, +2.4187, +2.4162, +2.4175, -50.00C, *77
00, 105.7, 000.447, -000.988, M, +346.09, +024.21, 00, +2.4181, +2.4187, +2.4162, +2.4175, -50.00C, *76
00, 086.6, 000.659, -001.124, M, +346.07, +024.18, 00, +2.4181, +2.4187, +2.4162, +2.4175, -50.00C, *7B
00, 086.5, 000.474, -000.658, M, +346.03, +024.11, 00, +2.4181, +2.4187, +2.4162, +2.4175, -50.00C, *75
00, 090.0, 000.470, -000.897, M, +346.03, +024.11, 00, +2.4181, +2.4187, +2.4162, +2.4175, -50.00C, *7E
00, 098.5, 000.421, -000.997, M, +346.09, +024.21, 00, +2.4181, +2.4187, +2.4162, +2.4175, -50.00C, *7F
00, 096.0, 000.339, -000.839, M, +346.11, +024.25, 00, +2.4181, +2.4187, +2.4162, +2.4175, -50.00C, *72
00, 106.5, 000.258, -000.764, M, +346.19, +024.38, 00, +2.4181, +2.4187, +2.4162, +2.4175, -50.00C, *7A
00, 095.6, 000.394, -001.061, M, +346.13, +024.28, 00, +2.4181, +2.4187, +2.4162, +2.4175, -50.00C, *7B
00, 110.6, 000.335, -000.982, M, +346.04, +024.13, 00, +2.4181, +2.4187, +2.4162, +2.4175, -50.00C, *77
00, 110.4, 000.399, -000.741, M, +345.99, +024.04, 00, +2.4181, +2.4187, +2.4169, +2.4175, -50.00C, *78
```

Checking the configuration

We recommend that, as a standard procedure, you use this command prior to, and after, changing any settings. It shows the current settings for most of the alterable settings.

The WindMaster responds with the current default settings. These are shown below:

We suggest you note down the settings, so that you can easily return to them.

Return to measurement mode

Settings and how to change them are explained in the following section.

Changing settings

To change a setting, refer to the sections below, and enter the command of the new setting required, followed by **ENTER**. If successful, the new setting will be sent back as a message by the WindMaster.

For example, to change the message format to UVW, Continuous, enter **M 1 ENTER**

The WindMaster will reply **M1**. When the unit is returned to the Measurement mode, it will be in UVW, Continuous format.

Note : The factory-set (default) settings are shown in bold in the following sections.

Command List

| COMMAND | USER |
|----------|--|
| A | SOS/Sonic Temp Output |
| B | Baud rate |
| C | Analogue angle wrapping |
| D | Diagnostic / Config info |
| E | Set Physical Comms |
| F | Signal Processing |
| G | Averaging Settings |
| H | Power on message |
| I | Disable/Enable analogue input |
| J | High/Low Resolution |
| K | Minimum Direction Velocity |
| L | Message Terminator |
| M | Message Format |
| N | Set Unit ID |
| O | Set ASCII format |
| P | Set output rate |
| Q | MEASUREMENT MODE |
| R | Not used |
| S | Analogue output range |
| T | Analogue output type & Config |
| U | Select Units |
| V | PRT output ON/OFF |
| W | Not Used |
| X | Axis Alignment |
| Y | Not Used |
| Z | Not used |
| * | INTERACTIVE MODE |

Where the command is a single parameter command the notation is Dx, for example if the parameter x = 2 then in interactive mode the user would type "D2".

Where the Command is dual parameter e.g. Fx y, then x selects the parameter and y turns it on or off (Fx<space>y).

Typing just the command letter will cause the current settings to be output.

Warning: Certain combinations of output rate, baud rate and message type may be unsupported.

Ax – Select SOS/Sonic Temp output

- | | |
|---|----------------|
| 1 | Neither |
| 2 | SOS |
| 3 | Sonic Temp |
| 4 | Both |

The SOS and/or Sonic Temp are displayed after the UNITS and before the status byte, the SOS is always in m/s and the Sonic Temp is always in deg C.

Bx – Set Baud rate

- | | |
|---|--------------|
| 1 | 2400 |
| 2 | 4800 |
| 3 | 9600 |
| 4 | 19200 |
| 5 | 38400 |
| 6 | 57600 |

If a request is sent to change the Baud rate, before it changes it must be confirmed by entering **B** **ENTER** at the new Baud rate.

E.g. If set to B3 (9600 baud), to change to B5 (38400 baud), enter **B** **5** **ENTER**, change host terminal to 38400 baud, and confirm by entering **B** **ENTER**.

NOTE: a random echo may be generated after the B5 confirmation

Certain combinations of output rate, baud rate and message type may be unsupported.

Cx – Analogue output polar direction wrapping

- | | |
|---|---|
| 1 | 540 degree wraparound on analogue output |
| 2 | 360 degree wraparound on analogue output |

Dx – Diagnostic and configuration information

- | | |
|---|----------------------------------|
| 1 | Request serial number |
| 2 | Request SW version |
| 3 | Request current configuration |
| 4 | - |
| 5 | - |
| 6 | - |
| 7 | Report DAC channel configuration |

Examples of Diagnostic information are as follows:

Request Serial Number

D1

W154503 or Y154503 (see Para 5.3 for explanation).

Request SW Version

D2

2329-700

Request Current Configuration

D3

M2,U1,O1,L1,P1,B4,H1,NQ,E1,T1,S1,C2,A1,I1,J1,V1,X1,G0,K50

Report DAC Channel Configuration.

D7

DAC CHAN 01, MODE 05, CONFIG 02

DAC CHAN 02, MODE 09, CONFIG 01

DAC CHAN 03, MODE 04, CONFIG 01

DAC CHAN 04, MODE 08, CONFIG 01

Where:-

Mode 01 = DAC Channel Off.

Mode 02 = U Magnitude Output.

Mode 03 = V Magnitude Output.

Mode 04 = W Magnitude Output.

Mode 05 = Polar Angle Output.

Mode 08 = Status (Good/Bad).

Mode 09 = Polar Magnitude Output.

and Configuration code for Mode 08 equates to good/bad status setting.

Config 01 = Good is high output level, Bad is low level.

Config 02 = Good is low output level, Bad is high level.

and Configuration codes for Modes 02, 03, 04, and 09 equate to scale setting:-

Config 01 = 5m/s

to

Config 08 = 120m/s

and Configuration code for Mode 5 equates to angle wrapping where:-

Config 01 = 540 degree wraparound.

Config 02 = 360 degree wraparound.

Ex Set Physical Communications

| | |
|---|------|
| 1 | AUTO |
| 2 | 485 |
| 3 | 232 |

It is recommended to leave the unit in AUTO mode. This can also be overridden from RS232 to RS422/485 by:-

On 31 way connector units without a Pipe Mount Box link the comms line to V+ for RS232 or to 0V for RS422/485.

On units fitted with a Pipe mount box if the link in the box is in its default position (see page 19) then the above external link connections apply.

On a unit fitted with a Pipe Mount box the internal link in the box may be moved to set R232 and RS422/RS485 operation (see Page 19). If the link is moved from its default position then an external wire link should not be used.

See section 6.6.1 and 6.6.2.

If a unit is set for E3 and required to be set back to E1 then with a HyperTerminal connection established go into Configuration Mode, Type E1 and Press Enter. Then Type E and Press Enter. Type Q and press Enter to go back into measurement mode.

Fx y Signal Processing

| Signal | x | Space | y |
|-----------------------------------|----------|-------|----------|
| Retries Off | 1 | | 0 |
| Retries On | 1 | | 1 |
| Instantaneous Sampling Off | 2 | | 0 |
| Instantaneous Sampling On | 2 | | 1 |
| Calibration Off | 3 | | 0 |
| Calibration On | 3 | | 1 |

Retries Enabled.

WindMaster Default setting is ON.

Enabled – If this mode is selected, if a problem sample is detected, the unit will attempt another ultrasonic firing within the set time parameters.

Disabled – The unit will not attempt to re-check problem samples.

11. Instantaneous Sampling

Default is OFF.

Enabled – The WindMaster can be configured to output the sampled data direct at the selected output rate without any averaging - "Instantaneous Sampling". If for example the sensor is set for 1Hz output rate then the unit will undertake one set of transducer firings and output the result after the 1 second period.

Disabled – Alternatively data can be sampled at 20Hz or 32Hz and averaged. This applies for wind data and speed of sound. All samples are transmitted with a status code.

If the sensor is for example set to 1 Hz output rate then the unit will undertake a full set of firings (at 20 Hz or 32Hz) and output the average result of them after the 1-second period.

12. Calibration Enabled

Default is ON.

Enabled – Generic data based on that collected during wind tunnel testing is programmed into an internal calibration table that is used to compensate for turbulence created around the spars and transducers.

Disabled – Turns off the calibration table data, there is no adjustment to take into account of turbulence around the spars and transducers and returns the unit to raw uncorrected operation.

Gx - (To be allocated for future developments)

Hx – Enable/Disable power on message

- | | |
|----------|---------------------------------|
| 1 | Power on message enabled |
| 2 | Power on message disabled |

If the power up message is On, then a message similar to that below is output, whenever the unit goes into Measurement mode (i.e. when power is first applied to the unit, or the unit returns to Measurement mode from Configuration mode).

WindMaster Pro 32Hz (SS) Gill Instruments Ltd

2329-700

RS232 (AUTO)

CHECKSUM ROM:9B50 9B50 *PASS*

CHECKSUM FAC:07BC 07BC *PASS*

CHECKSUM ENG:1E58 1E58 *PASS*

CHECKSUM CAL:3891 3891 *PASS*

If any of these checksums fail, the word PASS will be replaced by FAIL and the unit will use its default settings. If the checksum repeatedly fails after power on – contact your supplier.

Ix – Enable/Disable analogue input message

- | | |
|----------|---|
| 0 | Analogue input data off |
| 1 | Analogue input data on |
| 2 | Analogue inputs set for 2 Differential Mode pairs |

Jx – Set the unit Resolution

- | | |
|----------|---|
| 1 | Select Normal Resolution , 2 decimal point readings) |
| 2 | Select High Resolution, 3 decimal point readings) |

J2 High resolution is applicable to Wind Speed and Wind direction for Metres/sec setting only.

Kxx to Kxxxx Set Minimum direction velocity

This allows the minimum wind velocity to be set at which display of the direction is enabled in thousandth of a metre per second. The default is 50, which means that any wind magnitude <0.05m/s will have the wind direction omitted in polar mode. The maximum value allowed for this is 5000, or 5m/s.

- | | |
|-----------|---|
| 50 | Minimum direction velocity |
| 0 to 5000 | Select minimum direction velocity (in 0.001m/s steps) |

Lx – Message Terminator

- | | |
|----------|----------|
| 1 | <CR><LF> |
| 2 | <CR> |

Mx – Message Format

- | | |
|-----------|----------------------|
| 1 | UVW |
| 2 | Polar |
| 3 | UVW Polled |
| 4 | Polar Polled |
| 7 | Binary, Polar, Short |
| 8 | Binary, UVW, Short |
| 9 | Binary, Polar, Long |
| 10 | Binary, UVW, Long |

Nx – Set unit ID

Sets the unit ID displayed at the start of all GILL communications strings

Set **Q (default)**, ...from A to Z Command N<Q>

Ox – Set ASCII output format

- | |
|---|
| <ol style="list-style-type: none"> 1 Comma Separated Variable (CSV) format 2 Fixed field |
|---|

Example string for CSV data changing to an error status code condition.

□Q,335.3,001.261,-001.282,M,+345.41,+023.05,00,+2.4181,+2.4181,+2.4162,+2.4175,-50.00C,□78
 □Q,,M,,07,+2.4181,+2.4187,+2.4162,+2.4175,-50.00C,□72

Example string for Fixed Field data changing to an error status code condition.

□Q,251.7,000.860,-000.401,M,+346.43,+024.80,00,+2.4181,+2.4187,+2.4169,+2.4175,-50.00C,□7F
 □Q,999.9,999.999,+999.999,M,+999.99,+999.99,07,+2.4181,+2.4187,+2.4169,+2.4181,-50.00C,□77

Px – Set output rate

Note: the P9 setting is an option on the WindMaster unit, which must be specified at the time of ordering.

- | |
|---|
| <ol style="list-style-type: none"> 1 Rate is 1 Hz (20Hz Sampling) 2 Rate is 2 Hz (20Hz Sampling) 3 Rate is 4 Hz (20Hz Sampling) 4 Rate is 5 Hz (20Hz Sampling) 5 Rate is 8 Hz (32Hz Sampling) 6 Rate is 10 Hz (20Hz Sampling) 7 Rate is 16 Hz (32Hz Sampling) 8 Rate is 20 Hz (20Hz Sampling) 9 Rate is 32 Hz (32Hz Sampling) 20 Rate is ¼ Hz 21 Rate is ½ Hz |
|---|

Sx – Analogue output range

This sets the velocity scaling for the analogue output. (see also Para 9.5).

- | |
|---|
| <ol style="list-style-type: none"> 1 Full range is 5m/s 2 Full range is 10m/s 3 Full range is 20m/s 4 Full range is 30m/s 5 Full range is 40m/s 6 Full range is 50m/s 7 Full range is 60m/s 8 Full range is 120m/s |
|---|

Tx – Set analogue output type

Use Gill Wind Software to set required ranges

- | | |
|---|-----------------------|
| 1 | 0V to 5V range |
| 2 | -2.5V to 2.5V range |
| 3 | 4mA to 20mA range |
| 4 | -5V to 5V range |
| 5 | 0mA to 20mA range |

Ux – Set units

- | | |
|---|------------|
| 1 | m/s |
| 2 | Knots |
| 3 | MPH |
| 4 | KPH |
| 5 | FPM |

Vx – Enable/Disable PRT

- | | |
|---|------------|
| 1 | OFF |
| 2 | ON |

Note: PRT not an Option fitted to the WindMaster.

Xx – Axis Alignment

- | | |
|---|---|
| 1 | Align U Axis to unit North Spar (See Fig 2). |
| 2 | Align U to the top axis transducer 1 |
| 3 | Same as X1 but inverted for upside down operation |
| 4 | Same as X2 but inverted for upside down operation |

10.3 Viewing and logging WindMaster Data using Gill WindView Software.

WindView is supplied on the equipment CD but can also be downloaded from:-

<http://gillinstruments.com/main/software.html>

Open WindView and Select File/Connect.

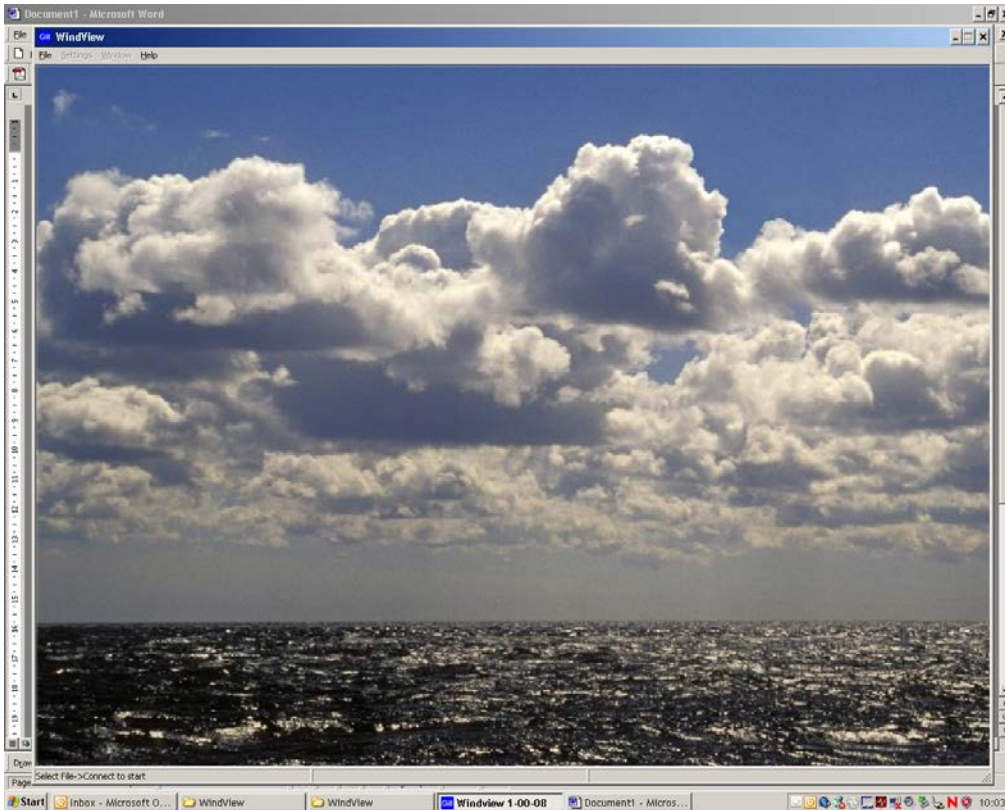

Select appropriate connection COM Port number and instrument Baud rate.

Select output format UV or Polar to match the WindMaster setting.

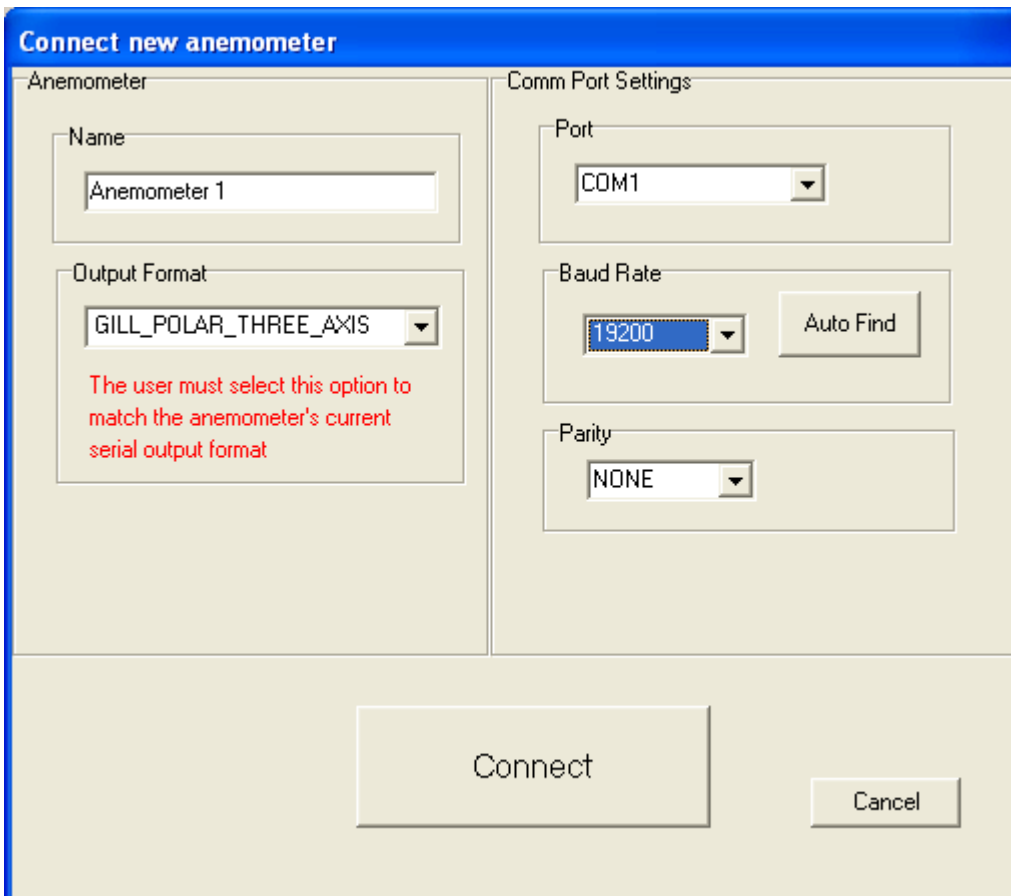

WindMaster 3 axis data will scroll on screen at the instruments output rate (2Hz shown).

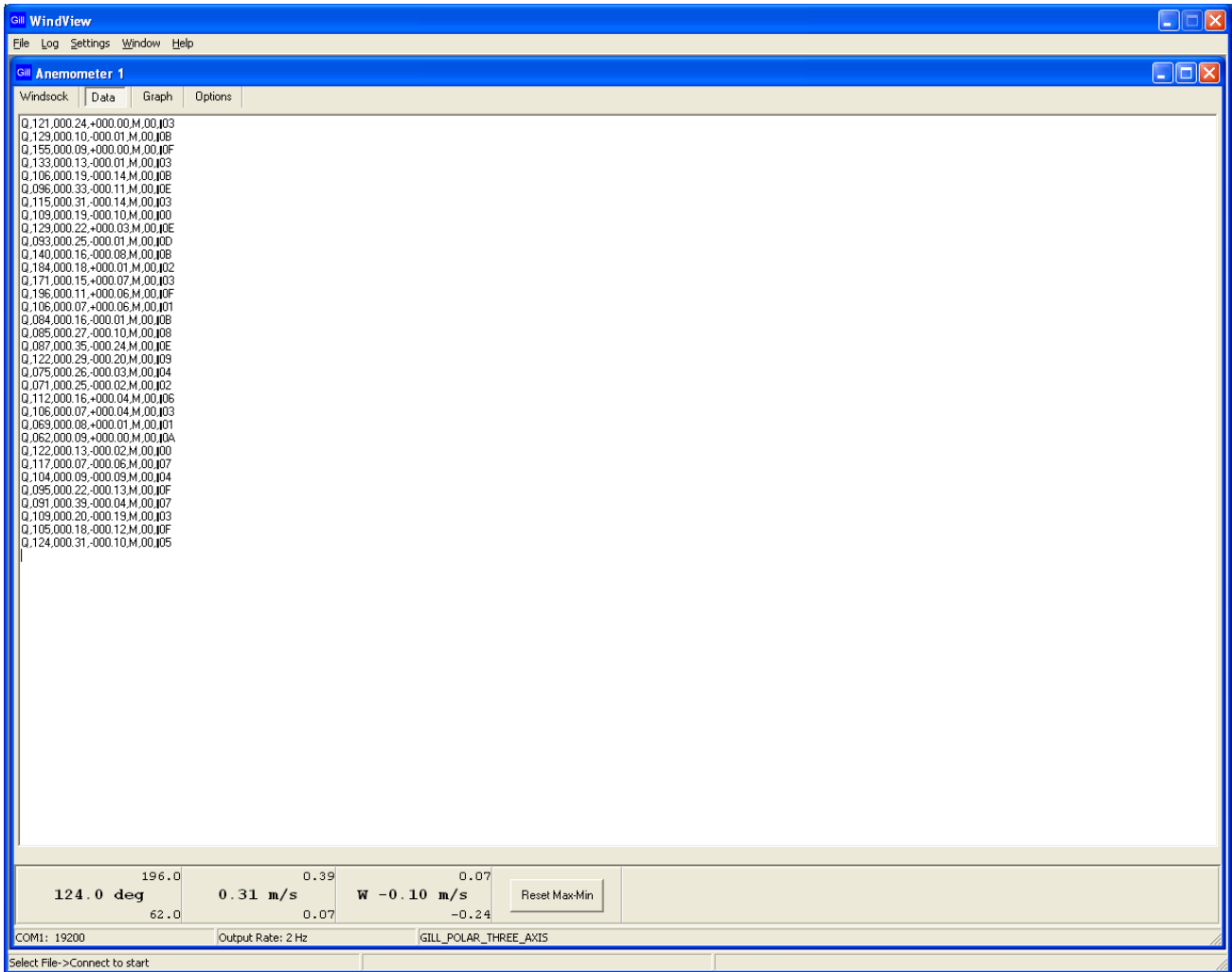

Click on the WindSock tab to see a graphical display of wind.

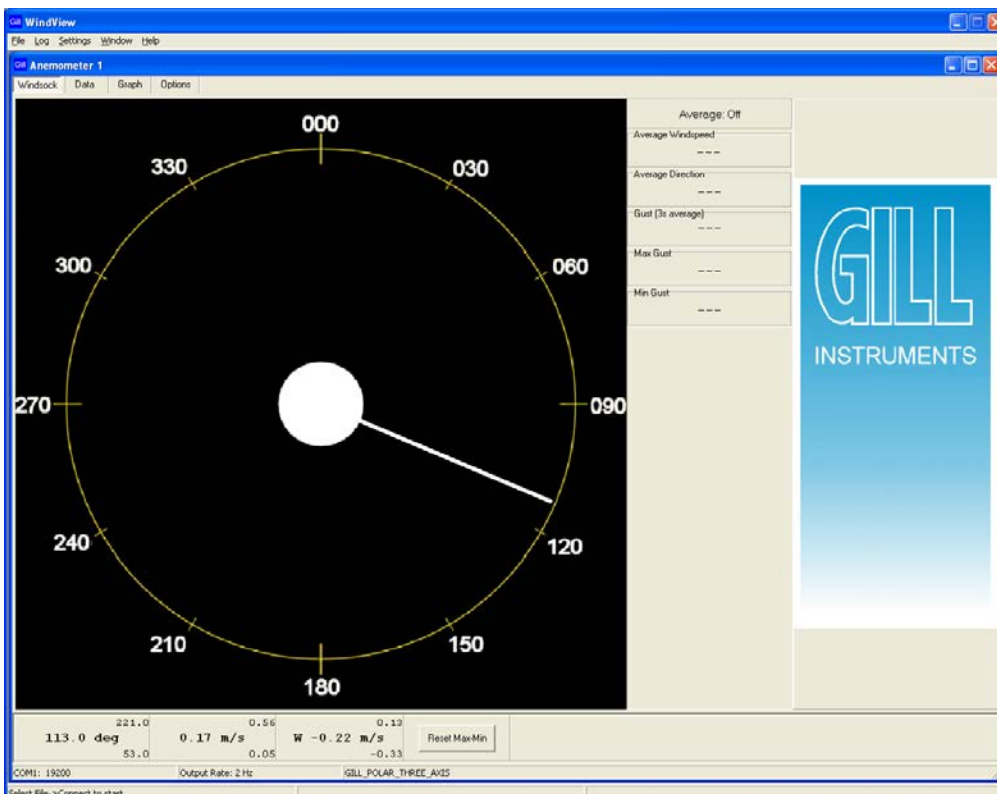

To Start Logging Data

Note: If logging fast data of 20Hz or more ensure that the WindMaster is set for at least 38400 bauds.

From the top menu click on Settings/Logging.

If segmented logging files are required tick Enable and set the time for creating each log file.

Append Time stamp/Append record count as required

A free text field is available for logging comments.

Select a file directory and Name

Click on Apply.

Follow Note instruction to start logging on the top Menu Select File/Log/Start.

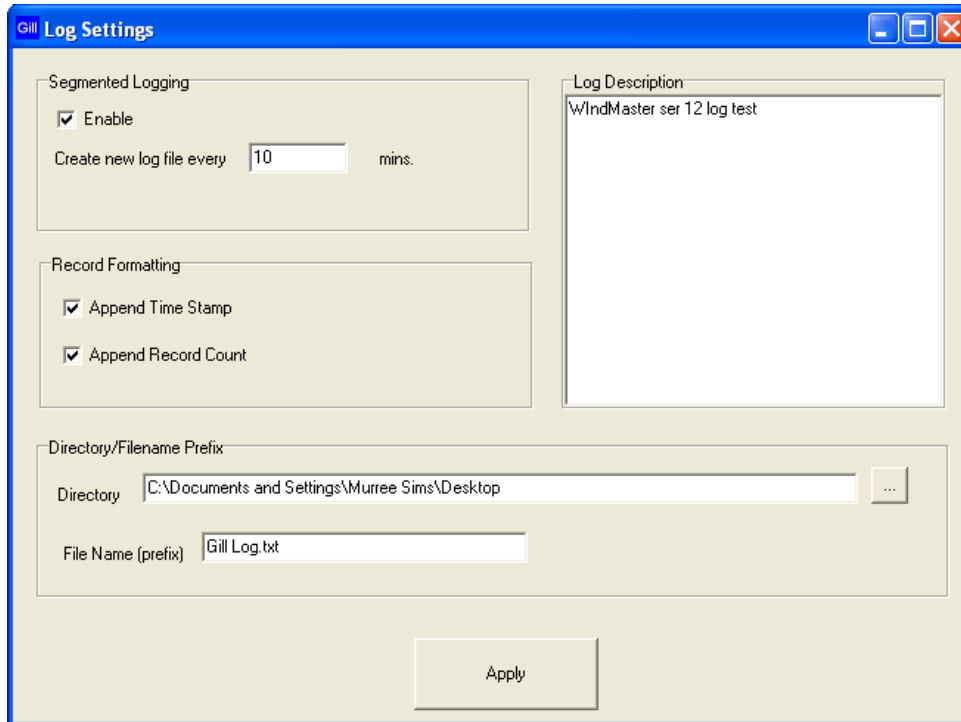

To Stop Logging Data

When logging is required to stop go to the Top menu, Select File/Log/Stop.

A typical logged Notepad file is as follows (WindMaster set for 2Hz output rate):-

```
Gill Log [Anemometer 1]-1.txt - Notepad
File Edit Format View Help
windview - [Anemometer 1] Log File
WindMaster ser 12 log test
Name: Anemometer 1
Output Format: GILL_POLAR_THREE_AXIS
Log file opened: 07/05/2010 15:42:17

Q, 050,000.28,-000.21,M,00,00D,1,07/05/2010 15:42:18
Q, 088,000.43,-000.19,M,00,00E,2,07/05/2010 15:42:18
Q, 123,000.37,-000.13,M,00,007,3,07/05/2010 15:42:19
Q, 121,000.32,-000.15,M,00,006,4,07/05/2010 15:42:19
Q, 087,000.30,-000.19,M,00,005,5,07/05/2010 15:42:20
Q, 099,000.38,-000.23,M,00,00B,6,07/05/2010 15:42:20
Q, 109,000.32,-000.10,M,00,009,7,07/05/2010 15:42:21
Q, 143,000.30,-000.07,M,00,003,8,07/05/2010 15:42:21
Q, 149,000.24,-000.07,M,00,00C,9,07/05/2010 15:42:22
Q, 155,000.20,-000.06,M,00,004,10,07/05/2010 15:42:22
Q, 182,000.16,-000.14,M,00,008,11,07/05/2010 15:42:23
Q, 190,000.16,-000.11,M,00,00E,12,07/05/2010 15:42:23
Q, 172,000.06,-000.12,M,00,000,13,07/05/2010 15:42:24
Q, 246,000.07,-000.06,M,00,000,14,07/05/2010 15:42:24
Q, 219,000.17,-000.01,M,00,00C,15,07/05/2010 15:42:25
Q, 202,000.16,+000.04,M,00,004,16,07/05/2010 15:42:25
Q, 245,000.05,+000.03,M,00,002,17,07/05/2010 15:42:26
Q, 193,000.13,+000.12,M,00,00D,18,07/05/2010 15:42:26
Q, 181,000.26,-000.03,M,00,00E,19,07/05/2010 15:42:27
Q, 152,000.06,-000.12,M,00,002,20,07/05/2010 15:42:27
Q, 065,000.10,-000.21,M,00,000,21,07/05/2010 15:42:28
Q, 249,000.12,-000.12,M,00,00E,22,07/05/2010 15:42:28
Q, 223,000.17,-000.04,M,00,000,23,07/05/2010 15:42:29
Q, 241,000.20,+000.03,M,00,001,24,07/05/2010 15:42:29
Q, 244,000.19,+000.02,M,00,00F,25,07/05/2010 15:42:30
Q, 227,000.16,+000.01,M,00,006,26,07/05/2010 15:42:30
```

11 MAINTENANCE & FAULT-FINDING

11.1 Cleaning

If there is any build-up of deposit on the unit, it should be gently cleaned with a cloth moistened with water and soft detergent. Solvents should not be used, and care should be taken to avoid scratching any surfaces. The unit must be allowed to defrost naturally after being exposed to snow or icy conditions, do NOT attempt to remove ice or snow with a tool.

11.2 Servicing

There are no moving parts or user-serviceable parts requiring routine maintenance.

Opening the unit or breaking the security seal will void the warranty and the calibration.

In the event of failure, prior to returning the unit to your authorised Gill distributor, it is recommended that:

1. All cables and connectors are checked for continuity, bad contacts, corrosion etc.
2. A bench test is carried out as described in Section 12.1.
3. You contact your supplier for advice

11.3 Fault-finding

| Symptom | Solution |
|---|--|
| No output | Check DC power to WindMaster, cable and connections. Check comms settings of WindMaster (<i>as detailed in Section 10</i>) and host system match, including correct Com port. Try using Gill Wind Software/Tools/Synch Comms Check unit is in Continuous mode Check that in-line communication devices are wired correctly. NOTE: It is usual for Anemometer TX to be connected to converter device RX |
| Corrupted output | Check comms settings of WindMaster and host system match. Try using Gill Wind Software/Tools/Synch Comms Try a slower baud rate. Check cable lengths and type of cable. |
| One way communication | Check WindMaster and host system are both set to the same protocol RS232, RS422, or RS485. Check wiring is in accordance with the manual. |
| Failed / Incorrect WindMaster output, data invalid flag | Check that transducer path is not blocked |

11.4 Status (error) codes

The Status code is sent as part of each wind measurement message.

| Code | Status | Condition |
|-----------|------------------------|--|
| 00 | OK | Functioning correctly |
| 01 | Sample failure | Insufficient samples in average period from transducer pair 1 |
| 02 | Sample Failure | Insufficient samples in average period from transducer pair 2 |
| 03 | Sample Failure | Insufficient samples in average period from transducer pair 3 |
| 04 | Sample Failure | Insufficient samples in average period from transducer pairs 1,2 |
| 05 | Sample Failure | Insufficient samples in average period from transducer pairs 1,3 |
| 06 | Sample Failure | Insufficient samples in average period from transducer pairs 2,3 |
| 07 | Sample Failure | Insufficient samples in average period from all transducer pairs |
| 08 | NVM Error | NVM Checksum failed |
| 09 | ROM Error | ROM checksum failed |
| 0A | System gain at Maximum | Results OK, but marginal operation |
| 0B | Retries | Retries used |

11.5 Returning units

If the unit has to be returned, it should be carefully packed in the original packaging and returned to your authorised Gill distributor, with a full description of the fault condition.

12 TESTS

12.1 Bench test

1. Couple the WindMaster to the host system and power supply, using a known working test cable.
2. Check that the unit is correctly configured (*see Section 10*).
3. Check for normal output data, and that the Status Code is OK – 00.
4. If the status code is other than 00 or 0A, refer to Section 11.5 Status (error) codes.
5. Use an office fan or similar to check that the unit is sensing wind, turning the unit to simulate changing wind direction and to check that all three axes are functioning.
6. Note that this a quick functional test. There are no calibration adjustments. *See 12.3*.

Note: Refer to Dx – diagnostic and configuration information for further self-tests

12.2 Head Alignment Test

A test is available that allows a Transducer Path Alignment test (D6) to be undertaken and that factors in room temperature.

NOTE 1: The maximum room test temperature is +22 deg C (minimum +14 degrees C).

NOTE 2: The test should be performed in a zero wind environment or as near as possible.

Setting up a WindMaster with HyperTerminal or equivalent Terminal Program.

Connect WindMaster (set/wired for RS232 or RS422/232/USB convertor in line) to the PC. Then open HyperTerminal as follows:-

Select a name for the connection e.g. Test. Click on OK.

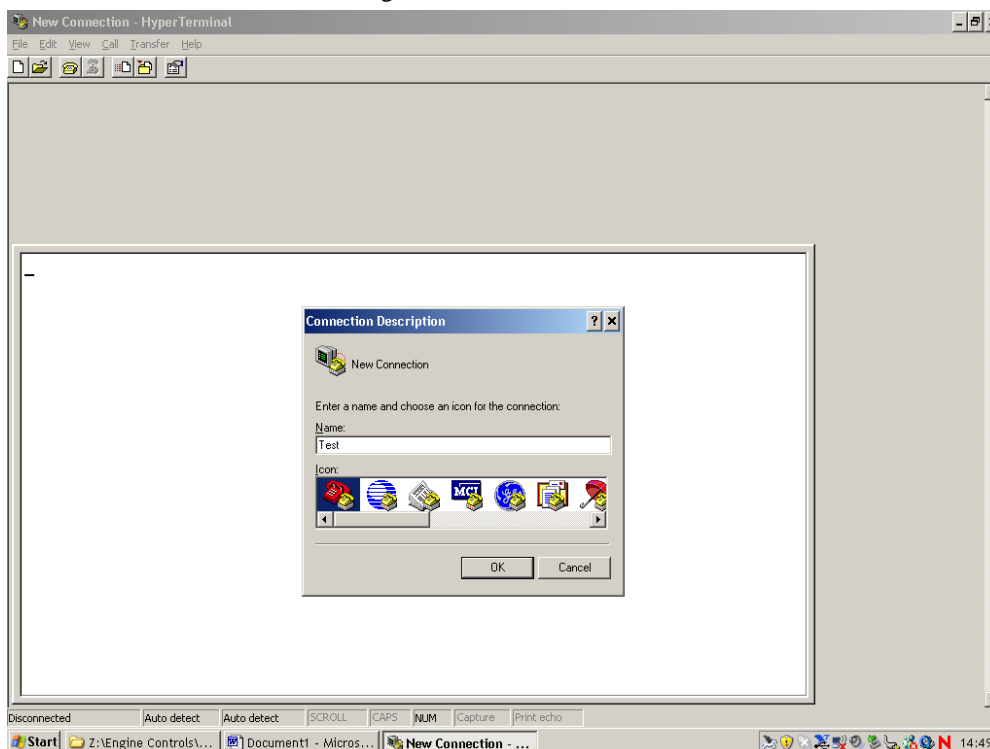

On the screen use the drop down menu for 'Connect using' and select COM1 Port or applicable COM port. Click OK.

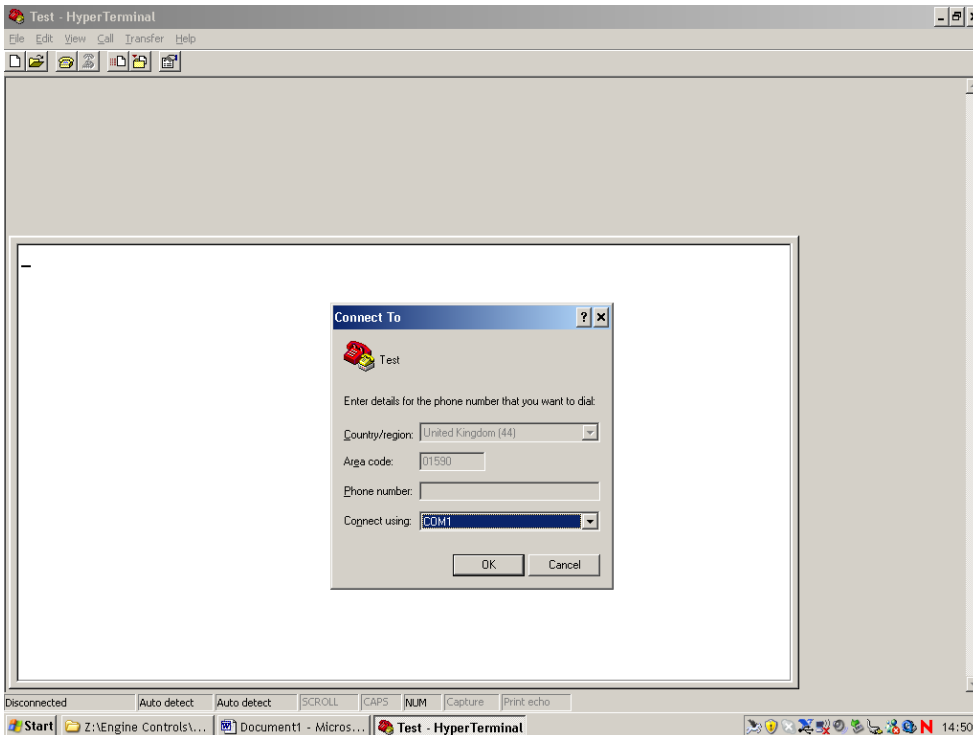

On the following screen.

Set Bits per second drop down menu to the appropriate WindMaster baud rate setting e.g. 19200 bauds is the default WindMaster setting.

Set Data Bits to 8.

Set Parity to None.

Set Stop Bits to 1.

Set Flow Control to None.

Click on OK.

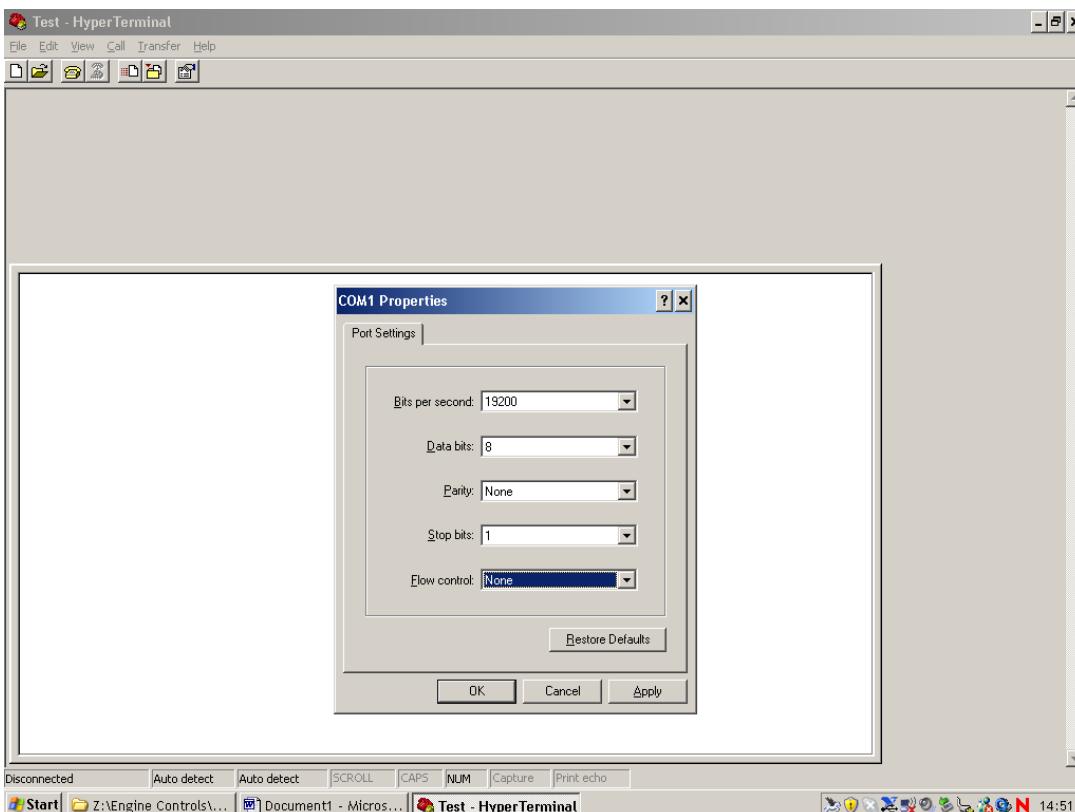

The WindMaster should be outputting data as per the following screen. **Note if strange characters or garbled data are seen try opening the HyperTerminal link at a different Baud rate (or connect the WindMaster in Wind to determine the Baud rate).**

```

00,000,000.02,-000.02,M,00,002
00,000,000.01,-000.01,M,00,002
00,000,000.01,-000.01,M,00,002
00,000,000.02,-000.03,M,00,003
00,000,000.04,-000.08,M,00,014
00,088,000.15,-000.12,M,00,005
00,096,001.05,-000.49,M,00,004
00,135,000.38,-000.28,M,00,004
00,145,000.38,-000.13,M,00,011
00,134,000.33,-000.05,M,00,001
00,190,000.09,-000.05,M,00,006
00,098,000.20,-000.23,M,00,000
00,099,000.73,-000.19,M,00,014
00,112,000.42,-000.21,M,00,005

```

To Communicate with the WindMaster:

Type * (or hold down star).

This will bring up the text CONFIGURATION MODE.

Type D1.

The unit will respond with the serial number.

Type D2.

The unit will respond with the Software version.

Type D3.

The unit will respond with the unit Configuration.

D6 Test

Type D6 xx and then press Enter where xx is the temperature in deg C between the limits 14 to 22 deg C.

So for instance if you have a room temperature of 21 deg C,

Type D6 21 and press Enter

Confirm that you get pass results as below, if Refer to Manual should still appear it is then likely that a path length is out of spec and the unit will need to be returned for investigation.

```

CHECKSUM ROM:9779 9779 *PASS*
CHECKSUM FAC:0AC3 0AC3 *PASS*
CHECKSUM ENG:254F 254F *PASS*
CHECKSUM CAL:3076 3076 *PASS*

D6 21
1:2863,27FF
2:280A,27A6
3:2888,2824
PATH 1:283C *PASS*
PATH 2:27EF *PASS*
PATH 3:285D *PASS*
GAIN 0:0005 *PASS*
GAIN 1:0005 *PASS*
GAIN 2:0005 *PASS*
GAIN 3:0005 *PASS*
GAIN 4:0005 *PASS*
GAIN 5:0005 *PASS*
CHECKSUM ROM:9779 9779 *PASS*
CHECKSUM FAC:0AC3 0AC3 *PASS*
CHECKSUM ENG:254F 254F *PASS*
CHECKSUM CAL:3076 3076 *PASS*

```

12.3 Calibration

Note - There are no in-use calibration adjustments; the unit is designed NOT to require re-calibration within its lifetime.

Standard calibration

Accuracy at 12 m/s Wind speed 1.5% RMS Direction 2°

Certified calibration

The unit can be Wind tunnel calibrated in accordance with ISO 16622 with traceability to national standards.

This should be specified when ordering, or the unit can be returned to Gill Instruments for retrospective calibration.

Accuracy at 12 m/s Wind speed 1% RMS Direction 0.5°

13 APPENDICES

13.1 Guarantee

For terms of guarantee contact your supplier.

Warranty is void if the green security seal covering base nuts is damaged or broken, or the transducer caps have been damaged.

13.2 Improvement Key Notes

The following are extracts from an amended Key Note Document regarding improvements to the WindMaster and WindMaster Range.

WindMaster™ PRO

| | |
|-------------------------------|---|
| Key Note Series Number | KN1508 |
| Subject | Improvements to the WindMaster Product Range (detailed amended) |
| Applicable models | WindMaster / WindMaster Pro |
| Date: | 5 th October 2015 (amended) |

Technical Improvements to WindMaster (WM) and WindMaster Pro (WM Pro) products from mid Oct. 2015 will provide:

WM and WM Pro products will receive the following improvements without any change to the transducers themselves or basic geometry/path lengths/measurements of the units, ensuring continuity of design and existing performance characteristics, while allowing significant improvements to some areas without any change to the known good behaviour of the products.

Sonic Temperature

Sonic temperature improvements:-

±2°C maximum error compared to reference quality ambient slow response (< 1 Hz) temperature measurements over an extended temperature range of -20°C to +30°C.

Fast response (1 Hz or faster) sonic temperature performance remains excellent and unchanged (Eddy Covariance Quality).

The improvements allow the WM/WM Pro users to consider using the sonic temperature output as a general thermometer reading where appropriate for ancillary measurements and to assist in H2O flux corrections without the need for additional thermometers (and associated errors/time series/different spatial locations). Previously, WM and WM Pro products could have as much as 6°C sonic temperature error compared to ambient reference measurements. Improvements have been made to the way the transducer stalk is mounted, the way the transducer is housed within the stalk, which in turn means less delay in the measurement and therefore better accuracy.

Removal of a non-linear error in slow response sonic temperature around 0°C:-

Previous WM/WM Pro products could, in some cases, have as much as 12°C total error between – 5°C and + 5°C ambient temperatures. The removal of this error makes any error in sonic temperature very easy to correct for using a simple ‘trend’ baseline correction, where desired (as the sonic temperature will be within ±2° of the baseline reference ambient temperature).

Again, the improvements come from production process improvements (better automation and repeatability due to higher volume production, along with improvements to the way the transducer is housed in the stalk and frame of the anemometer.) This improvement will greatly assist the flux community with research in cold environments looking at small scale flux onset around 0°C with better results and less correction needed.

W Correction

In addition to the sonic temperature improvements, the following significant 'w' corrections are also being introduced to the WM / WM Pro range. Gill found a 'bug' in the WindMaster and WindMaster Pro firmware (previously unknown to both Gill and the community) from internal research looking at Angle of Attack (AoA) corrections for various wind vectors. The 'bug' is effectively that there is no mechanical 'maths' correction applied for the vertical 'w' axis wind measurement. All other Gill 3 axis anemometers have this 'w' correction implemented correctly. The correction being introduced with this 3 dimensional head is a significant boost in the 'w' wind component (compared to previous outputs from the WM / WM Pro) which can be seen below:

+W correction +16.6% (multiplication factor of $\times 1.166$).

-W correction +28.9% (multiplication factor of $\times 1.289$).

This correction will provide excellent 3 dimensional wind accuracy results within stated specification wind speed and incidence angle from horizontal. (± 30 degrees). In addition, this correction will assist in providing better accuracy at AoA greater than ± 30 degrees, although with decreasing benefit, up to ± 60 degrees from horizontal.

It has always been the case that users can measure 3 dimensional wind flows using Gill 3 Axis products without any head correction applied (so no u, v or w correction). Using Gill Wind software allows the user to disable Calibration to collect data in a 'raw' mode without any correction and also to allow users to decide if they wish to apply any recent AoA (Angle of Attack) corrections being developed by the community (Nakai et al, 2012, for example). Users of Gill WM/WM Pro products will be able to post process collected data to include the above 'w' improvements where desired, and Gill will work with the community to enable this process upon request and mutual discussion.

See the following table for more information on what corrections are applied regarding Gill products and revisions. Contact Gill if you have any questions in this regard.

The above correction only affects the W Vector, it does not affect Polar or UV wind readings in either digital or analogue forms.

General

The above improvements have been available from mid-October 2015 onwards and are already implemented in the WindMaster HS product. Gill provide the above Sonic temperature and W improvements free of charge with any current purchase. Please contact Gill Instruments for further details regarding upgrading of existing products should this be of interest.

Part numbers of the WindMaster and WindMaster Pro with the above improvements will be identified with a /W suffix (e.g. 1590-PK-020/W). Users will also be able to check via software the firmware pre-fix which will identify which of the above improvements that their unit will have (2329-601 or lower for legacy and 2329-700 or higher for improved units).

13.3 Nakai 2012 Correction Information

| Model | Taro Nakai (2012) applicable? (Eddy Pro software feature) | Nomenclature for AoA analysis | Identifying differences between WindMaster/Pro Anemometers | | | | | Gill Corrections that are applied | | | | AoA validity specification (from Horizontal flow) | Calibration can be turned on/off? |
|--|--|-------------------------------|--|-----------------|--------------|-----------------|--------------------------|-----------------------------------|--|--|---------------------|---|-----------------------------------|
| | | | Dates in production | Spar colour | Stalk colour | Bosses | Electronic Serial Number | uv- plane Calibration | Calibration Type (generic/individual/both) | uv- plane correction for AoA (3-theta) | w correction factor | | |
| WindMaster 1590-PK-020/W and 1590-PK-050 | Principle sound however incorrect coefficients (WM 'w' bug boost correction included) also requires review of Gill's symmetry data from tunnel testing against Nakai's existing field data; this may require further field testing | WM(W) | From Oct 2015 | Blue | Black | Aluminium | Starts with Wxxxxxx | Yes | Both | No | Yes | ±30° | Yes |
| WindMaster 1590-PK-020 | YES, however requires review of Gill's symmetry data from tunnel testing against Nakai's existing field data; this may require further field testing | WM | From 2006 | Blue | Black | Aluminium | Starts with Yxxxxxx | Yes | Both | No | Yes | ±30° | Yes |
| WindMaster Pro 1561-PK-020/W | Principle sound however incorrect coefficients (WM 'w' bug boost correction included) also requires review of Gill's symmetry data from tunnel testing against Nakai's existing field data; this may require further field testing | WMPro(W) | From Oct 2015 | Stainless Steel | Black | Stainless Steel | Starts with Wxxxxxx | Yes | Both | No | Yes | ±30° | Yes |
| WindMaster Pro 1561-PK-020 | YES, however requires review of Gill's symmetry data from tunnel testing against Nakai's existing field data; this may require further field testing | WMPro | From 2006 | Stainless Steel | Black | Stainless Steel | Starts with Yxxxxxx | Yes | Both | No | Yes | ±30° | Yes |

